

A

Application

Series D1V hydraulic directional control valves are high performance, direct operated 4-way valves. They are available in 2 or 3-position styles. They are manifold mounted valves, which conform to NFPA's D03, CETOP 3 mounting pattern. These valves were designed for industrial and mobile hydraulic applications which require high cycle rates, long life and high efficiency.

Operation

Series D1V directional control valves consist of a 4-chamber style body, and a case hardened sliding spool. The spool is directly shifted by a variety of operators including: solenoid, lever, cam, air or oil pilots.

D1VW Solenoid Operated Plug-In Conduit Box Style

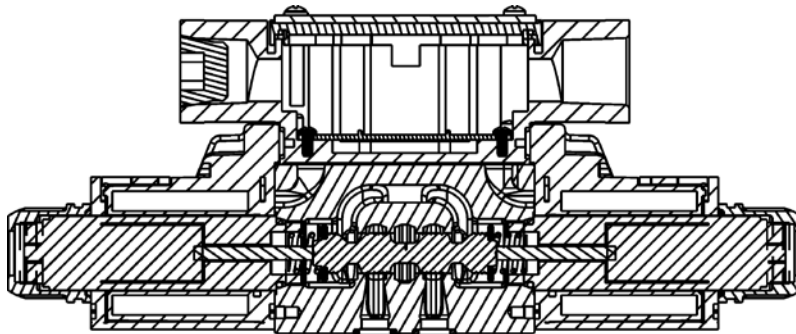

- Easy access mounting bolts.
- Waterproof NEMA 4, IP67.
- No tools required for coil removal.
- 19 standard spool styles available.
- Four electrical connection options.
- Lights included (CSA approval for DC solenoids and lights).
- Easy coil replacement.
- Plug-In design offered with lights & other options.

D1VW Solenoid Operated Hirschmann (DIN) Style

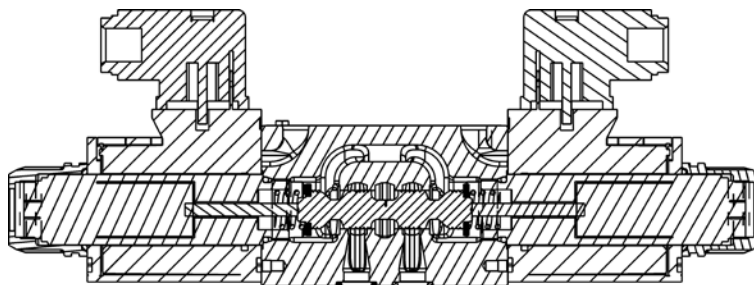

- DIN Style (43650) Hirschmann.
- 19 spool styles available.
- No tools required for coil removal.
- Easy coil replacement.
- AC & DC lights available. (CSA approval for solenoids and lights).

D1VP Oil Pilot Operated

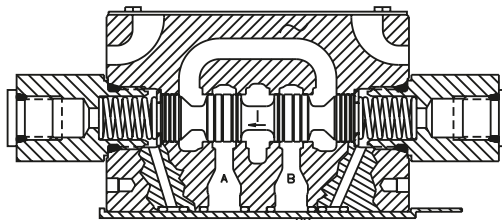

- Subplate pilot or end cap pilot option.
- Pilot pressure: 15.2 Bar (220 PSI) to 207 Bar (3000 PSI).



Electrical Connections

Series D1V valves may be configured in all popular electrical configurations including:

Plug-in Conduit Box	Explosion Proof	Dual Spade (DC only)
DESINA (DC only)	Hirschmann (DIN)	Wire Lead Conduit Box
Deutsch (DC only)	Metri-Pack (DC only)	

D1VW Solenoid Operated Wire Lead Conduit Box Style

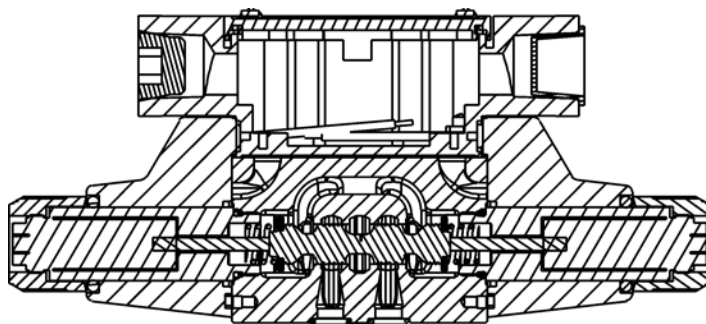

- Easy access mounting bolts.
- Waterproof NEMA 4, IP67.
- No tools required for coil removal.
- 19 spool styles available.
- No lights available

D1VW Solenoid Operated DESINA Style

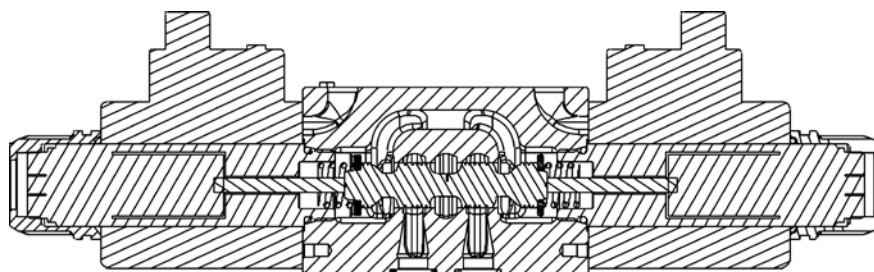

- Surge suppression standard.
- 19 standard spool available.
- No tools required for spool removal.
- Easy coil replacement.
- Wired to DESINA Spec (VDMA).
- Lights included.

D1VW Solenoid Operated Dual Spade Style

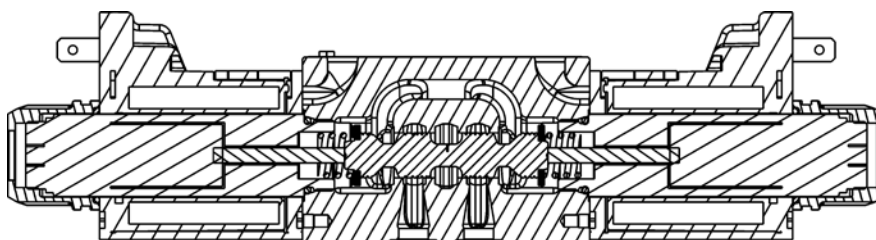

- Dual spade connection (SAE Style 1B).
- Easy coil replacement.
- Surge suppression available.
- 19 standard spool styles available.

A**Features**

- Easy access mounting bolts.
- 345 Bar (5000 PSI) pressure rating.
- Flows to 22 GPM depending on spool.
- Choice of five operator styles.
- Rugged four land spools.
- Low pressure drop.
- Phosphate finished body.
- CSA approved and U.L. recognized available.
- Optional proportional spool available.
- Optional painted body.

D1VL Lever Operated

- Spring return or detent styles available.
- Heavy duty handle design.

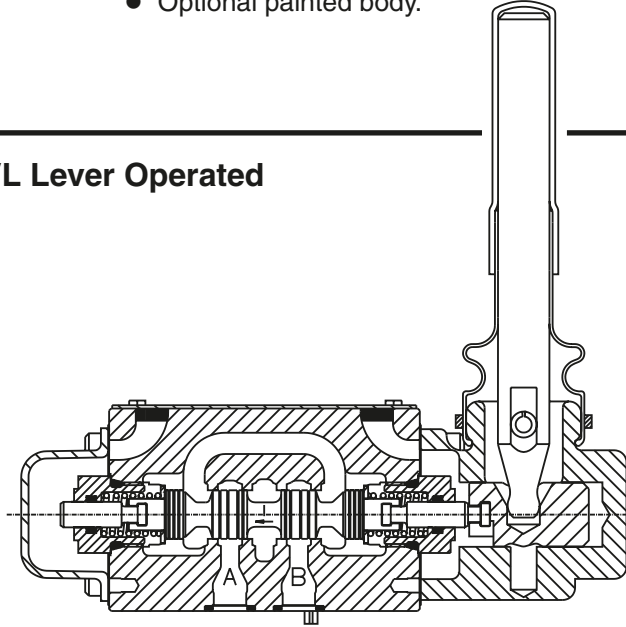
**D1VA Air Operated**

- Low pilot pressure required – 4.1 Bar (60 PSI) minimum.

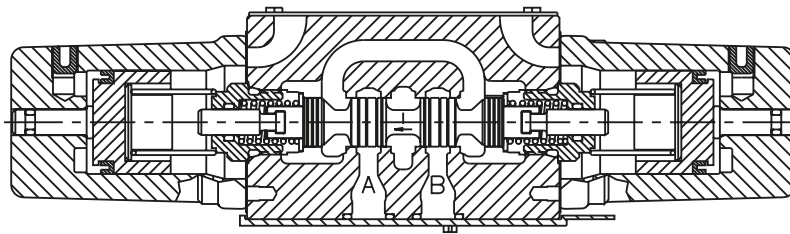
**D1VC Cam Operated**

- Choice of 2 cam roller positions (D1VC and D1VD).
- Two styles available (D1VC and D1VG).
- Short stroke option.

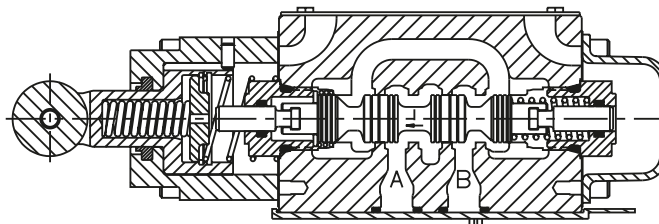

D1VW AC Solenoid Operated Soft Shift

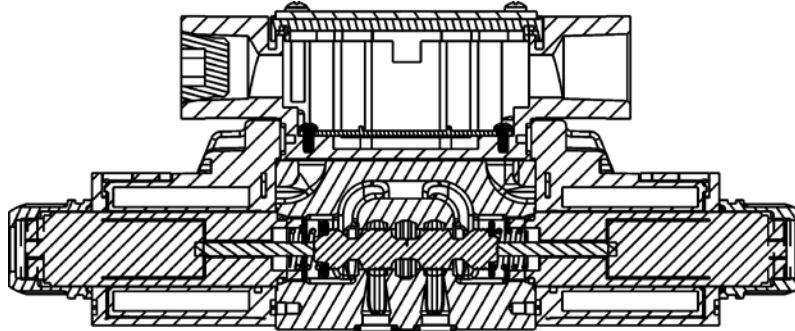

- 4 standard orifice sizes available.
- 19 spool styles available.
- AC Rectified or DC input.

D1VW DC Solenoid Operated Soft Shift

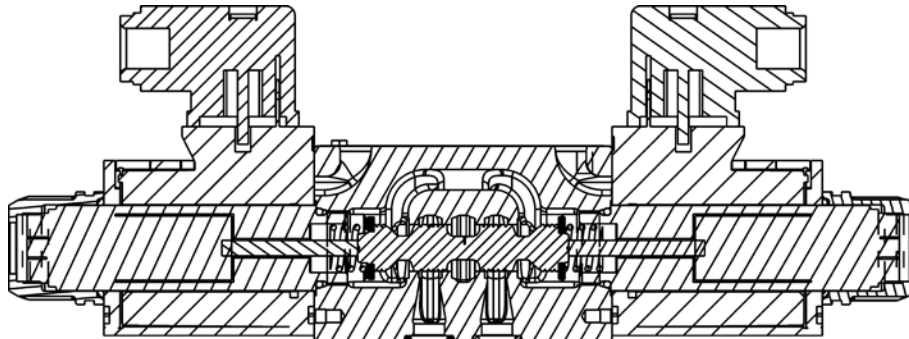

Standard Spool Reference Data

A

Model	Spool Symbol	Maximum Flow, LPM (GPM) 350 Bar (5000 PSI) w/o Malfunction		
		High Watt DC	Low Watt AC	Low Watt DC
D1V*001		78 (20)	49 (13)	37 (10)
D1V*002		78 (20)	45 (12)	68 (18)
D1V*003		70 (18)	30 (8)	34 (9)
D1V*004		37 (10)	30 (8)	68 (18)
D1V*005		60 (16)	45 (12)	45 (12)
D1V*006		79 (21)	49 (13)	52 (14)
D1V*007		45 (12)	18 (5)	18 (5)
D1V*008		49 (13)	45 (12)	37 (10)
D1V*009		58 (15)	45 (12)	45 (12)
D1V*010		13 (4)	11 (3)	15 (4)
D1V*011		58 (16)	30 (8)	37 (10)
D1V*014		45 (12)	18 (5)	18 (5)
D1V*015		79 (21)	30 (8)	34 (9)
D1V*016		60 (16)	45 (12)	52 (14)
D1V*020		78 (20)	45 (12)	75 (20)
D1V*026		37 (10)	11 (3)	7 (2)
D1V*030		70 (18)	18 (5)	75 (20)
D1V*081		32 (9)	26 (7)	30 (8)
D1V*082		32 (9)	26 (7)	34 (9)

Center or De-energized position is indicated by P, A, B & T port notation.

D1VA, D1VP, D1VC, D1VL Reference Data

Model	Spool Symbol	Maximum Flow, LPM (GPM) 350 Bar (5000 PSI) w/o Malfunction	Model	Spool Symbol	Maximum Flow, LPM (GPM) 350 Bar (5000 PSI) w/o Malfunction
D1V*1		83 (22)	D1V*20 #		53 (14)
D1V*2		83 (22)	D1V*26 #		11 (3)
D1V*4		45 (12)	D1V*30 #		19 (5)
D1V*8		45 (12)	D1V*81		30 (8)
D1V*9		57 (15)	D1V*82		30 (8)

Center or De-energized position is indicated by A, B, P & T port notation.
 # D1VP only.



Manaplug – Electrical Mini Plug

- EP336-30 3 Pin Plug
- EP316-30 5 Pin Plug (Double Solenoid)
- EP31A-30 5 Pin Plug (Single Solenoid)

Desina – 12mm Connector

5004109

Monitor Switch Connector

1301903-N

Manaplug – Electrical Micro Plug

- EP337-30 3 Pin Plug
- EP317-30 5 Pin Plug (Double Solenoid)
- EP31B-30 5 Pin Plug (Single Solenoid)

Electrical Cords – Mini Plug

- EC 3 Conductor, 6 ft.
- EC3 3 Conductor, 3 ft.
- EC12 3 Conductor, 12 ft.
- EC5 5 Conductor, 6 ft.
- EC53 5 Conductor, 3 ft.
- EC512 5 Conductor, 12 ft.

Hirschmann – Female Connector

- 692915 Gray (Solenoid A)
- 692914 Black (Solenoid B)

Quantity Required		
A,C,D	B,E,F	H,K,M
1	–	1
1	1	–

Hirschmann – Female Connector-Rectified (48-240 VAC)

- 1301053 Gray (Solenoid A)
- 1301054 Black (Solenoid B)

1	–	1
1	1	–

Hirschmann – Female Connector-Rectified w/Lights (100-240 VAC)

1300712

2	1	1
---	---	---

Hirschmann – Female Connector w/Lights (Note Voltages)

- 694935 6-48 VAC or VDC
- 694936 48-120 VDC, 100-240 VAC

2	1	1
2	1	1

D1.indd, dd





Solenoid Ratings

Insulation System	Class F
Allowable Deviation from rated voltage	-15% to +10% for DC and AC rectified coils -5% to +5% for AC Coils
Armature	Wet pin type
CSA File Number	LR60407
Environmental Capability	DC Solenoids meet NEMA 4 and IP67 when properly wired and installed. Contact HVD for AC coil applications.

Explosion Proof Solenoid Ratings*

U.L. & CSA (EU)	Class I, Div 1 & 2, Groups C & D Class II, Div 1 & 2, Groups E, F & G As defined by the N.E.C.
MSHA (EO)	Complies with 30CFR, Part 18
ATEX (ED)	Complies with ATEX requirements for: Exd, Group IIB; EN50014: 1999+ Amds. 1 & 2, EN50018: 2000
ATEX & CSA/US (ET)	Complies with ATEX EN60079-0, EN60079-1 Ex d IIC; CSA/US Ex d IIC, AEx d IIC for Class I, Zone 1, UL1203, UL1604, CSA E61241,1 Class II, Div 1

* Allowable Voltage Deviation ±10%.
 Note that Explosion Proof AC coils are single frequency only.

Code		Voltage	In Rush Amps Amperage	In Rush VA	Holding Amps @ 3MM	Watts	Resistance
Voltage Code	Power Code						
D	L	120 VDC	N/A	N/A	0.09 Amps	10 W	1584.00 ohms
D	Omit	120 VDC	N/A	N/A	0.26 Amps	30 W	528.00 ohms
G	Omit	198 VDC	N/A	N/A	0.15 Amps	30 W	1306.80 ohms
J	L	24 VDC	N/A	N/A	0.44 Amps	10 W	51.89 ohms
J	Omit	24 VDC	N/A	N/A	1.32 Amps	30 W	17.27 ohms
K	L	12 VDC	N/A	N/A	0.88 Amps	10 W	12.97 ohms
K	Omit	12 VDC	N/A	N/A	2.64 Amps	30 W	4.32 ohms
L	L	6 VDC	N/A	N/A	1.67 Amps	10 W	3.59 ohms
L	Omit	6 VDC	N/A	N/A	5.00 Amps	30 W	1.20 ohms
Q	Omit	100 VAC / 60 Hz	2.05 Amps	170 VA	0.77 Amps	30 W	19.24 ohms
QD	F	100 VAC / 60 Hz	1.35 Amps	135 VA	0.41 Amps	18 W	31.20 ohms
QD	F	100 VAC / 50 Hz	1.50 Amps	150 VA	0.57 Amps	24 W	31.20 ohms
R	F	24/60 VAC, Low Watt	6.67 Amps	160 VA	2.20 Amps	23 W	1.52 ohms
T	Omit	240/60 VAC	0.83 Amps	199 VA	0.30 Amps	30 W	120.40 ohms
T	Omit	220/50 VAC	0.87 Amps	191 VA	0.34 Amps	30 W	120.40 ohms
T	F	240/60 VAC, Low Watt	0.70 Amps	168 VA	0.22 Amps	21 W	145.00 ohms
T	F	220/50 VAC, Low Watt	0.75 Amps	165 VA	0.26 Amps	23 W	145.00 ohms
U	L	98 VDC	N/A	N/A	0.10 Amps	10 W	960.00 ohms
U	Omit	98 VDC	N/A	N/A	0.31 Amps	30W	288.00 ohms
Y	Omit	120/60 VAC	1.7 Amps	204 VA	0.60 Amps	30 W	28.20 ohms
Y	Omit	110/50 VAC	1.7 Amps	187 VA	0.68 Amps	30 W	28.20 ohms
Y	F	120/60 VAC, Low Watt	1.40 Amps	168 VA	0.42 Amps	21 W	36.50 ohms
Y	F	110/50 VAC, Low Watt	1.50 Amps	165 VA	0.50 Amps	23 W	36.50 ohms
Z	L	250 VDC	N/A	N/A	0.04 Amps	10 W	6875.00 ohms
Z	Omit	250 VDC	N/A	N/A	0.13 Amps	30 W	1889.64 ohms
Explosion Proof Solenoids							
R		24/60 VAC	7.63 Amps	183 VA	2.85 Amps	27 W	1.99 ohms
T		240/60 VAC	0.76 Amps	183 VA	0.29 Amps	27 W	1.34 ohms
N		220/50 VAC	0.77 Amps	169 VA	0.31 Amps	27 W	1.38 ohms
Y		120/60 VAC	1.60 Amps	192 VA	0.58 Amps	27 W	33.50 ohms
P		110/50 VAC	1.47 Amps	162 VA	0.57 Amps	27 W	34.70 ohms
K		12 VDC	N/A	N/A	2.75 Amps	33 W	4.36 ohms
J		24 VDC	N/A	N/A	1.38 Amps	33 W	17.33 ohms
"ET" Explosion Proof Solenoids							
K		12 VDC	N/A	N/A	1.00 Amps	12 W	12.00 ohms
J		24 VDC	N/A	N/A	1.00 Amps	13 W	44.30 ohms
Y		120/60-50 VAC	N/A	N/A	0.16 Amps	17 W	667.00 ohms

D1.indd, dd



D1V Shift Limits, DC & AC Rectified 30 Watt

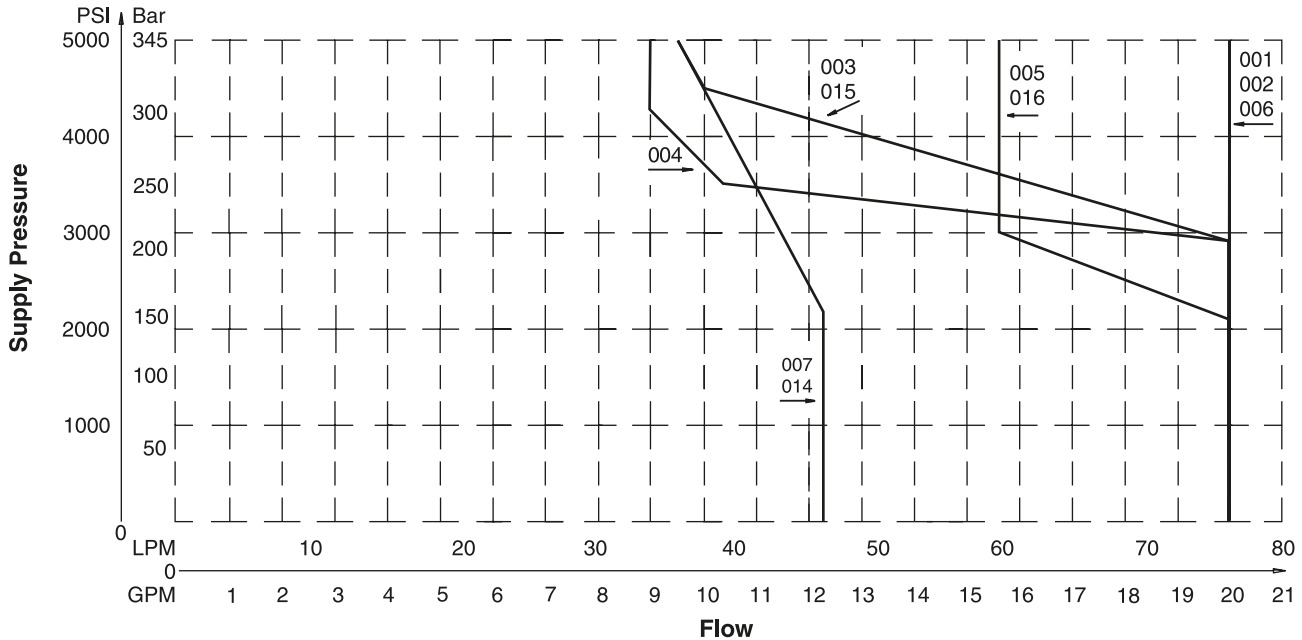

Example:

Determine the maximum allowable flow of a Series D1V valve (#004 spool) at 138 Bar (2000 PSI) supply pressure. Locate the curve marked "004". At 138 Bar (2000 PSI) supply pressure, the maximum flow is 57 LPM (15 GPM). At 207 Bar (3000 PSI), the flow is 49 LPM (13 GPM).

Important Notes for Switching Limit Charts

1. For F & M style valves, reduce flow to 70% of that shown.
2. Shift limits charted for equal flow A and B ports. Unequal A and B port flows may reduce shift limits.
3. These charts do not show explosion proof performance. Consult factory for explosion proof duty.
4. Blocking A or B ports will reduce flow by 70%.

D1VW***L Shift Limits**

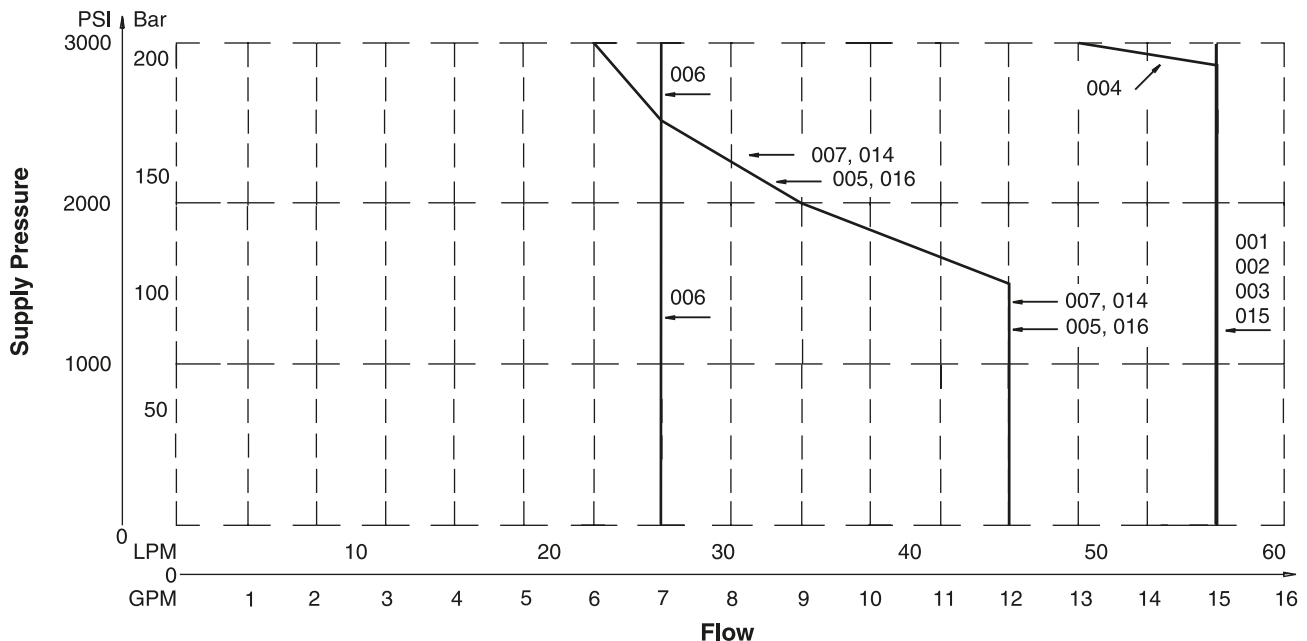

D1V Shift Limits, DC & AC Rectified 30 Watt

A

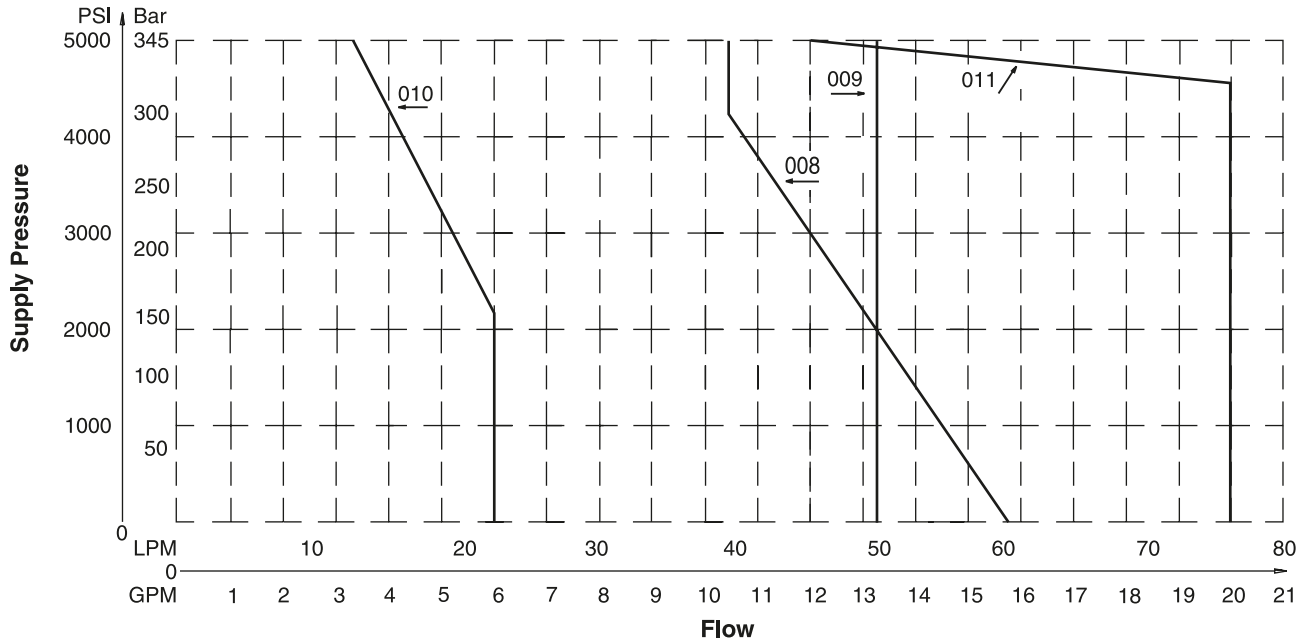

Example:

Determine the maximum allowable flow of a Series D1V valve (#008 spool) at 83 Bar (1200 PSI) supply pressure. Locate the curve marked "008". At 83 Bar (1200 PSI) supply pressure, the maximum flow is 57 LPM (15 GPM). At 207 Bar (3000 PSI), the flow is 19 LPM (5 GPM).

Important Notes for Switching Limit Charts

1. For F & M style valves, reduce flow to 70% of that shown.
2. Shift limits charted for equal flow A and B ports. Unequal A and B port flows may reduce shift limits.
3. These charts do not show explosion proof performance. Consult factory for explosion proof duty.
4. Blocking A or B ports will reduce flow by 70%.

D1VW***L Shift Limits**

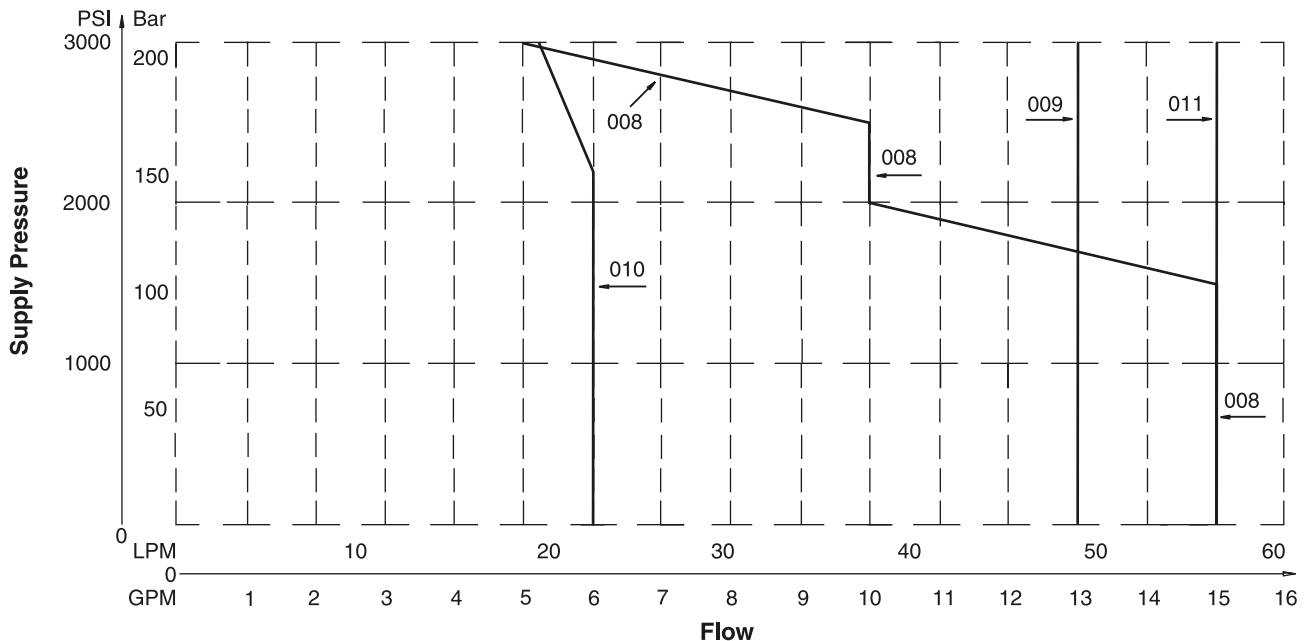



D1V Shift Limits, DC & AC Rectified 30 Watt

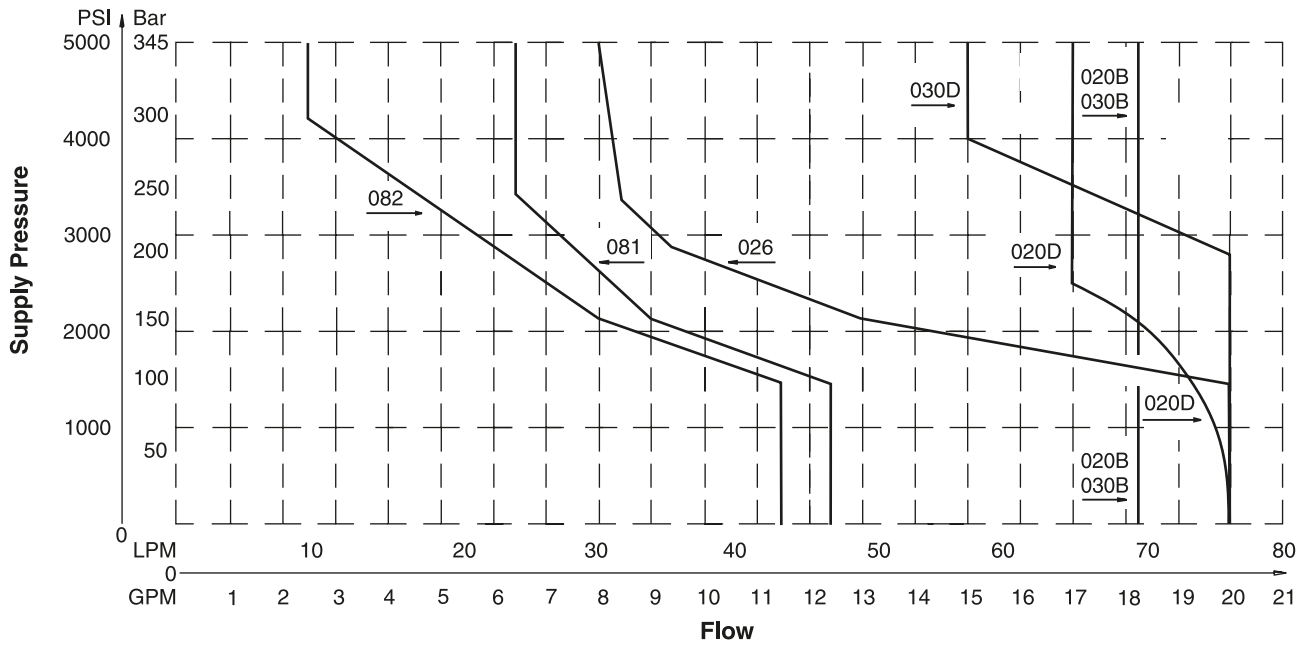

Example:

Determine the maximum allowable flow of a Series D1V valve (#081 spool) at 83 Bar (1200 PSI) supply pressure. Locate the curve marked "081". At 83 Bar (1200 PSI) supply pressure, the maximum flow is 42 LPM (11 GPM). At 138 Bar (2000 PSI), the flow is 42 LPM (11 GPM).

Important Notes for Switching Limit Charts

1. For F & M style valves, reduce flow to 70% of that shown.
2. Shift limits charted for equal flow A and B ports. Unequal A and B port flows may reduce shift limits.
3. These charts do not show explosion proof performance. Consult factory for explosion proof duty.
4. Blocking A or B ports will reduce flow by 70%.

D1VW***L Shift Limits**

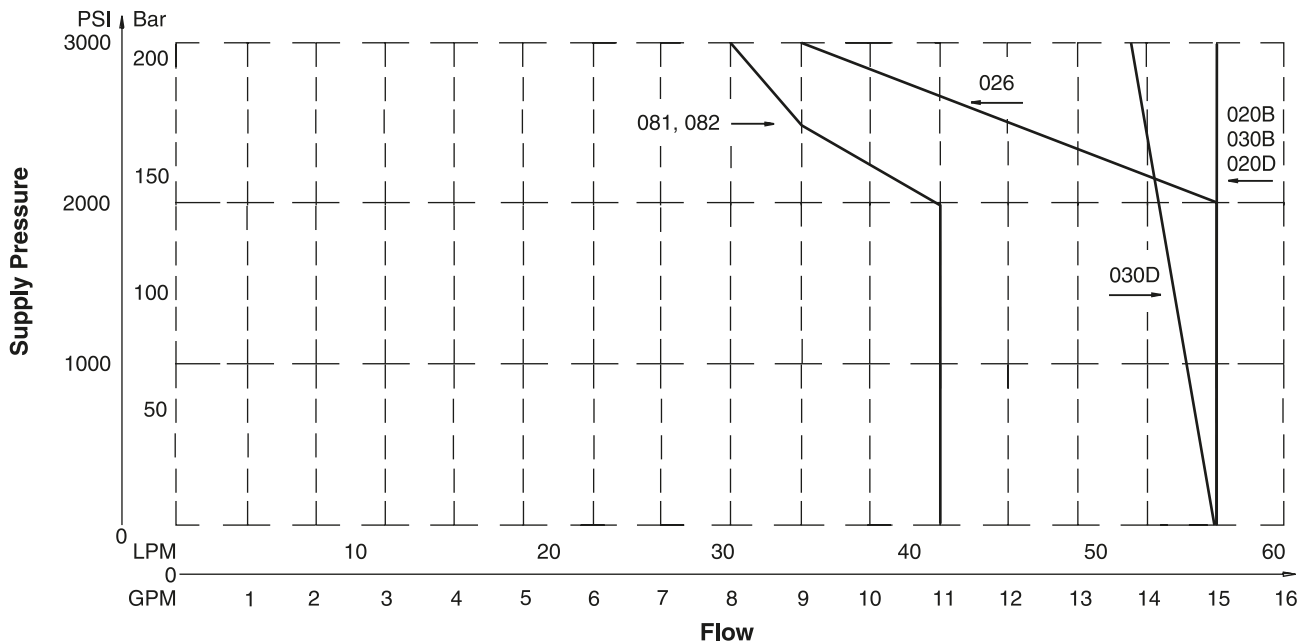

D1V Shift Limits, AC 30 Watt

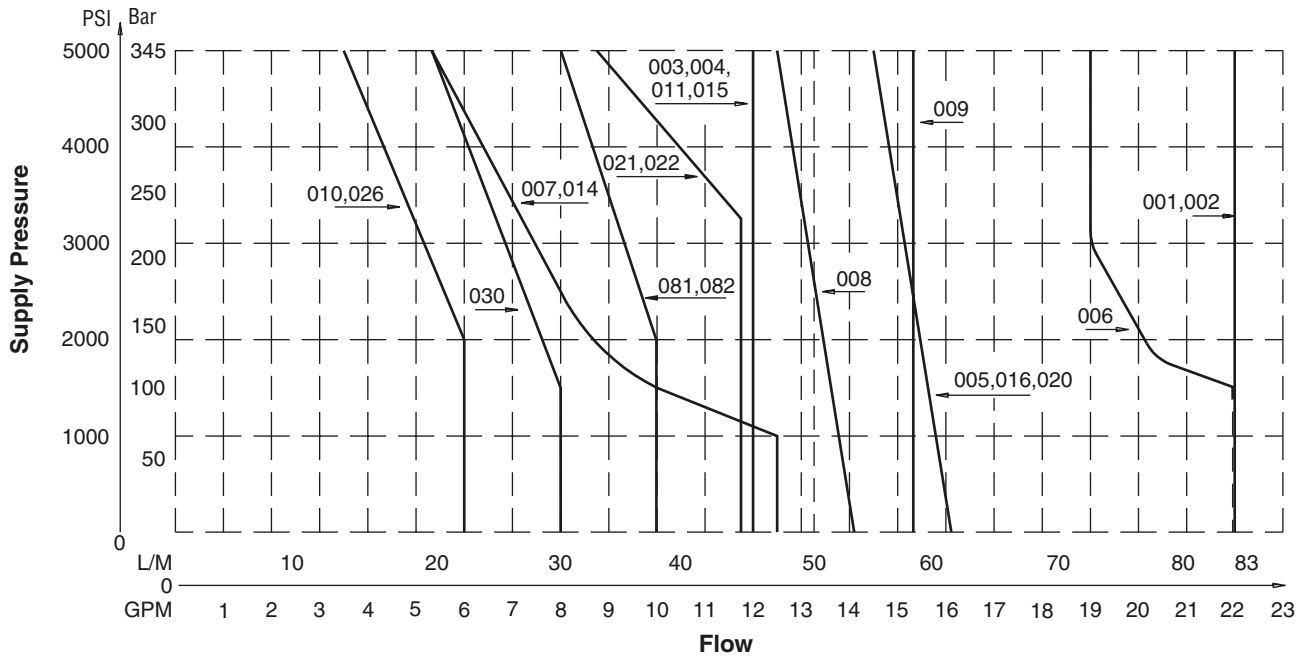

D1VW***F Shift Limits, AC**

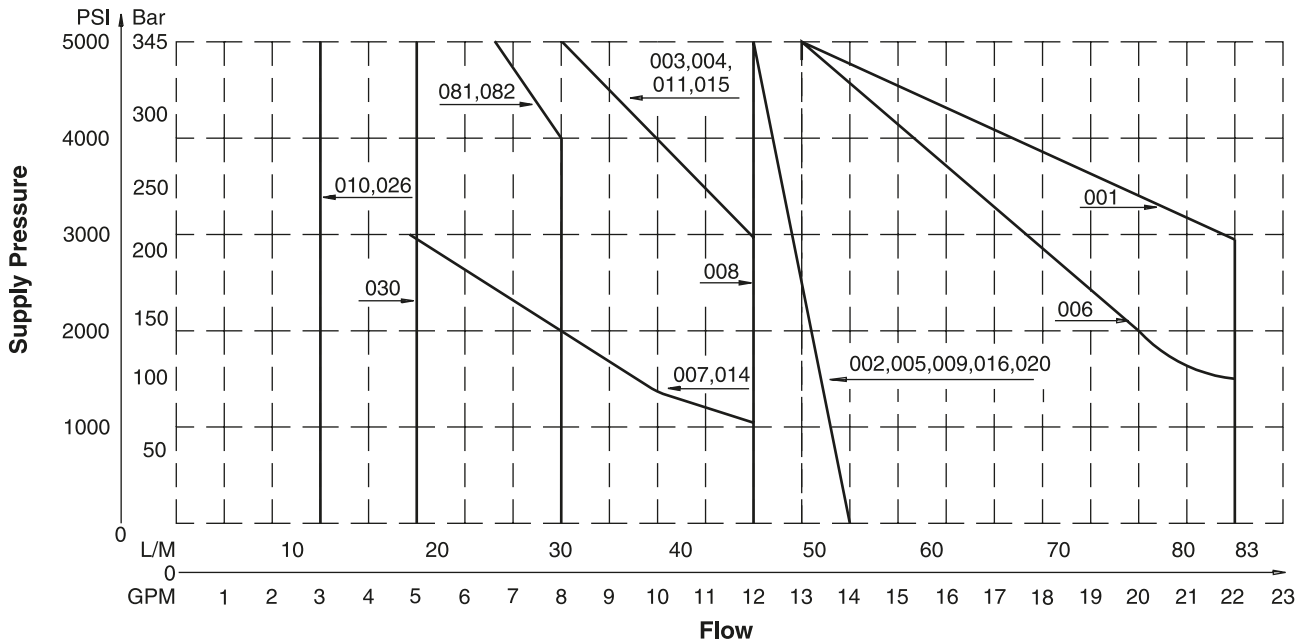

Example:

Determine the maximum allowable flow of a Series D1V valve (#009 spool) at 83 Bar (1200 PSI) supply pressure. Locate the curve marked "009". At 83 Bar (1200 PSI) supply pressure, the maximum flow is 75 LPM (20 GPM). At 207 Bar (3000 PSI), the flow is 68 LPM (18 GPM).

Important Notes for Switching Limit Charts

1. For F & M style valves, reduce flow to 70% of that shown.
2. Shift limits charted for equal flow A and B ports. Unequal A and B port flows may reduce shift limits.
3. These charts do not show explosion proof performance. Consult factory for explosion proof duty.
4. Blocking A or B ports will reduce flow by 70%.

Soft Shift Limit Curves

DC Power Supply

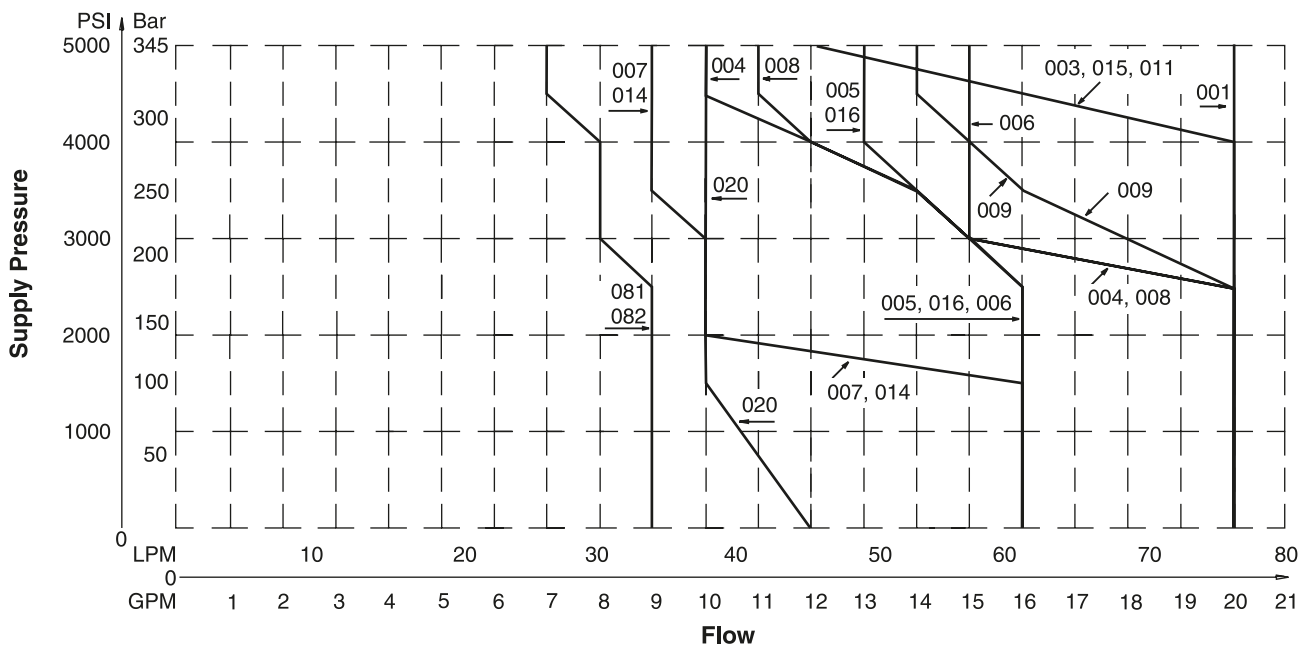

Pressure Drop vs. Flow, High Watt

A

The table to the right provides the flow vs. pressure drop curve reference for standard and high performance D1V Series valves by spool type.

The chart below demonstrates graphically the pressure drop characteristics of the standard D1VW****F and the high performance D1V. The low watt coil and other design features of the standard D1VW****F accommodate a maximum flow of 50 LPM (13 GPM) at 345 Bar (5000 PSI).

D1VW Pressure Drop Reference Chart – 30 Watt Coil

Spool No.	Curve Number										
	Shifted				Center Condition						
	P-A	P-B	B-T	A-T	(P-T)	(B-A)	(A-B)	(P-A)	(P-B)	(A-T)	(B-T)
001	3	3	2	2	—	—	—	—	—	—	—
002	2	2	1	1	2	1	1	1	1	1	1
003	2	2	1	1	—	—	—	—	—	1	—
004	2	2	1	1	—	—	—	—	—	2	2
005	2	3	1	1	—	—	—	5	—	—	—
006	2	2	1	1	—	6	6	6	6	—	—
007	2	3	1	1	4	—	1	—	—	—	—
008	5	5	5	5	5	—	—	—	—	—	—
009	4	4	4	4	4	—	—	—	—	—	—
010	3	3	—	—	—	—	—	—	—	—	—
011	3	3	1	1	—	—	—	—	—	8	8
014	3	2	1	1	4	1	—	—	—	—	—
015	2	2	1	1	—	—	—	—	—	—	1
016	3	2	1	1	—	—	—	—	5	—	—
020	4	4	2	2	—	—	—	—	—	—	—
026	4	4	—	—	—	—	—	—	—	—	—
030	2	2	1	1	—	—	—	—	—	—	—
081	7	7	8	8	—	—	—	—	—	—	—
082	7	7	8	8	—	—	—	—	—	—	—

Viscosity Correction Factor

Viscosity (SSU)	75	150	200	250	300	350	400	Curves were generated using 100 SSU hydraulic oil. For any other viscosity, pressure drop will change per chart. Pressure drops charted for equal flow A and B ports. Unequal A and B port flows may decrease shift limits.
% of ΔP (Approx.)	93	111	119	126	132	137	141	

Performance Curves – 30 Watt Coil

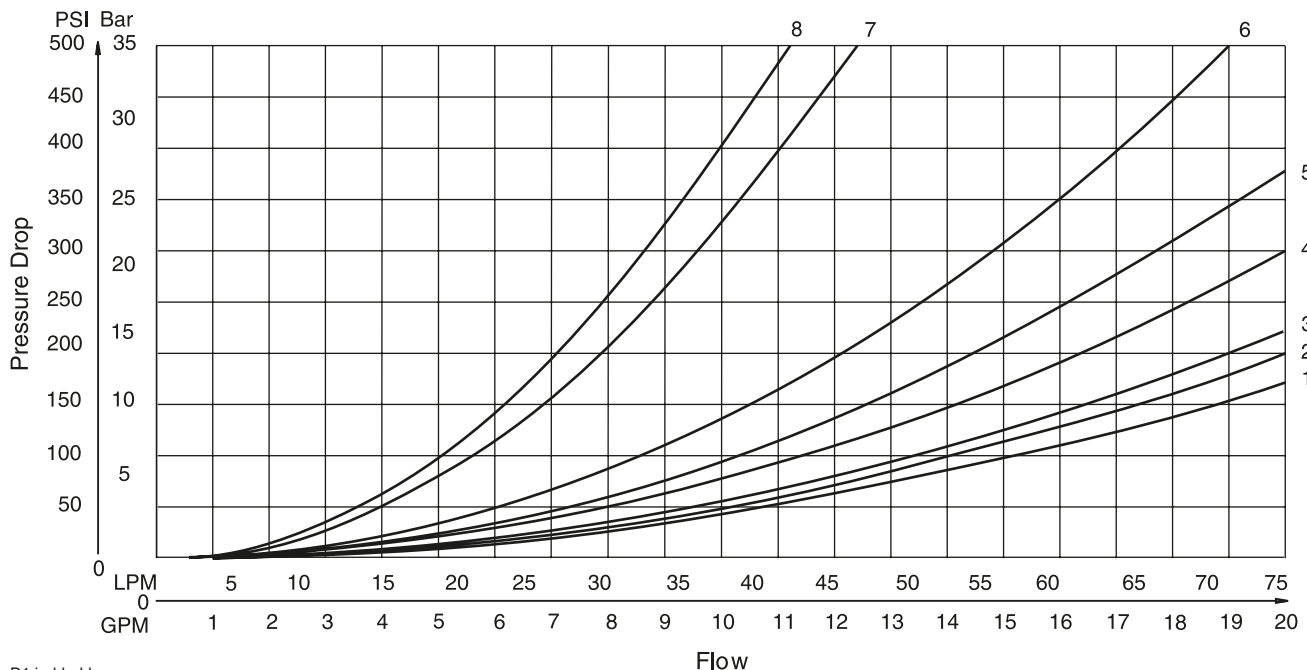

D1.indd, dd

Pressure Drop vs. Flow, Low Watt

The table to the right provides the flow vs. pressure drop curve reference for 10 watt D1V Series valves by spool type.

The chart below demonstrates graphically the pressure drop characteristics of the standard D1VW****L and the high performance D1V. The low watt coil and other design features of the standard D1VW****L accommodate a maximum flow of 50 LPM (13 GPM) at 345 Bar (5000 PSI).

D1VW Pressure Drop Reference Chart – 10 Watt Coil

Spool No.	Curve Number											
	Shifted				Center Condition							
	P-A	P-B	B-T	A-T	(P-T)	(B-A)	(A-B)	(P-A)	(P-B)	(A-T)	(B-T)	
001	3	3	2	2	—	—	—	—	—	—	—	
002	2	2	1	1	2	2	2	2	2	1	1	
003	3	3	2	1	—	—	—	—	—	4	—	
004	3	3	1	1	—	—	—	—	—	6	6	
005	3	3	1	1	—	—	—	7	—	—	—	
006	3	3	1	1	—	8	8	7	7	—	—	
007	3	3	1	1	5	—	4	—	—	—	1	
008	5	5	6	6	7	—	—	—	—	—	—	
009	6	6	6	6	5	—	—	—	—	—	—	
010	4	4	—	—	—	—	—	—	—	—	—	
011	3	3	1	1	—	—	—	—	—	11	11	
014	3	3	1	1	4	—	—	2	—	1	—	
015	3	3	1	2	—	—	—	—	—	—	4	
016	3	3	1	1	—	—	—	—	7	—	—	
020	7	7	4	4	—	—	—	—	—	—	—	
026	6	6	—	—	—	—	—	—	—	—	—	
030	2	2	1	1	—	—	—	—	—	—	—	
081	9	9	10	10	—	—	—	—	—	—	—	
082	10	10	10	10	—	—	—	—	—	—	—	



Viscosity Correction Factor

Viscosity (SSU)	75	150	200	250	300	350	400
% of ΔP (Approx.)	93	111	119	126	132	137	141

Curves were generated using 100 SSU hydraulic oil.
 For any other viscosity, pressure drop will change per chart.

Performance Curves – 10 Watt Coil

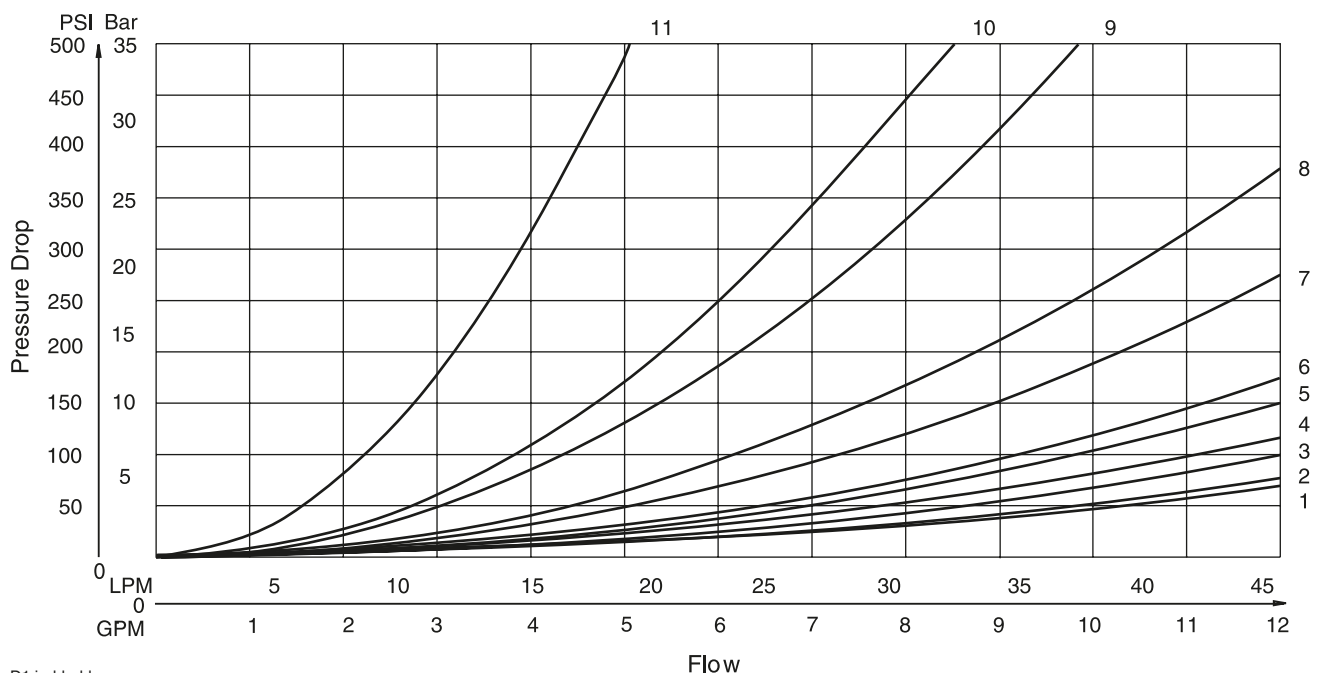

D1.indd, dd



General Description

Series D1VW directional control valves are high performance, 4-chamber, direct operated, wet armature solenoid controlled, 3 or 4-way valves. They are available in 2 or 3-position and conform to NFPA's D03, CETOP 3 mounting patterns.

Features

- Soft shift available.
- 19 standard spool styles available (for other spools – Consult Factory).
- Proportional spools.
- DC surge suppression.
- Eight electrical connection options.
- AC & DC lights available (CSA approval for solenoids and lights).
- Internally ground.
- Easy access mounting bolts.
- Waterproof (meets NEMA 4, up to IP67 on some models).
- Explosion proof.
- CSA approvals.

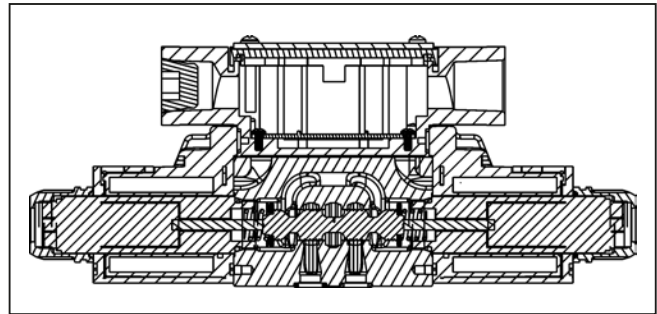
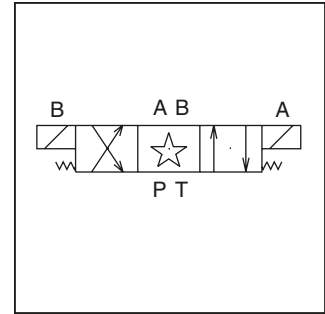
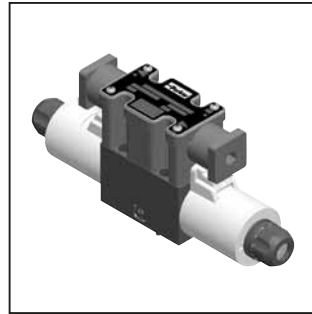

- U.L. recognized available - Contact the division.
- No tools required for coil removal.
- AC rectified coils.

Specifications

Mounting Pattern	NFPA D03, CETOP 3, NG 6	Leakage Rates* 100 SSU @ 49°C (120°F)	Maximum Allowable: 19.7 cc (1.2 Cu. in.) per Minute/Land @ 69 Bar (1000 PSI)* 73.8 cc (4.5 Cu. in.) per Minute/Land @ 207 Bar (3000 PSI)*
Mounting Interface	DIN 24340-A6 ISO 4401-AB-03-4-A CETOP R35H 4.2-4-03, NFPA D03		
Maximum Pressure	P, A, B 345 Bar (5000 PSI) Standard 207 Bar (3000 PSI) 10 Watt CSA 276 Bar (3750 PSI) Tank: 103 Bar (1500 PSI) AC only 207 Bar (3000 PSI) DC/AC Rectified Standard 207 Bar (3000 PSI) AC Optional CSA 103 Bar (1500 PSI)	*#008 and #009 Spools may exceed these rates. Consult Factory	Typical: 4.9 cc (0.3 Cu. in.) per Minute/Land @ 69 Bar (1000 PSI)* 26.2 cc (1.6 Cu. in.) per Minute/Land @ 345 Bar (5000 PSI)

Response Time

Response time (milliseconds) at 345 Bar (5000 PSI) is 32 LPM (8.5 GPM).

Solenoid Type	Pull-In	Drop-Out
AC	13	20
DC 10 Watt	61	22
DC 30 Watt	51	21

	Orifice Size	Spool Center Condition					
		Closed		Open		2-Position	
Soft Shift		Energize	De-Energize	Energize	De-Energize	Energize	De-Energize
S2	0.020	125 ms	920 ms	200 ms	275 ms	51 ms	100 ms
S5	0.050	51 ms	675 ms	50 ms	27 ms	51 ms	21 ms



A

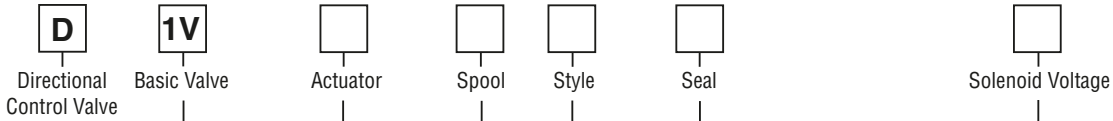

NFPA D03
 CETOP 3
 DIN NG6

Code	Description
W*	Solenoid, Wet Pin, Screw-in
HW*	Reversed Wiring

Code	Description
N	Nitrile
V	Fluorocarbon
E*	EPR

Code	Description	Code	Description
A**	24/50 VAC	Q**	100/60 VAC
D	120 VDC	QD†	100/60 - 100/50 VAC
G	198 VDC	R	24/60 VAC
J	24 VDC	T	240/60 - 220/50 VAC
K	12 VDC	U	98 VDC
L	6 VDC	Y	120/60 - 110/50 VAC
N***	220/50 VAC	Z	250 VDC
P***	110/50 VAC		

* Valve schematic symbols are per NFPA/ANSI standards, providing flow P to A when energizing solenoid A. Note operators reverse sides for #008 and #009 spools. See installation information for details. To configure per DIN standards (A coil over A port, B coil over B port) code valves as D1VHW***.

** High Watt only
 *** Explosion Proof only.
 † Available in DIN only.

Code	Symbol	Code	Symbol
001		011	
002		014	
003		015	
004		016	
005		020*	
006		026*	
007		030**	
008*, 009**		081	
010		082	

* 008, 020 & 026 spools have closed crossover.
 ** 009 & 030 spools have open crossover.

Code	Description	Symbol
B*	Single solenoid, 2 position, spring offset. P to A and B to T in offset position.	
C	Double solenoid, 3 position, spring centered.	
D†	Double solenoid, 2 position, detent.	
E	Single solenoid, 2 position, spring centered. P to B and A to T when energized.	
F‡	Single solenoid, 2 position. Spring offset, energized to center. Position spool spacer on A side. P to A and B to T in spring offset position.	
H*	Single solenoid, 2 position, spring offset. P to B and A to T in offset position.	
K	Single solenoid, 2 position, spring centered. P to A and B to T when energized.	
M‡	Single solenoid, 2 position, spring offset, energized to center position. Spool spacer on B side. P to B and A to T in spring offset position.	

* 020, 026 and 030 spools only.
 † 020 and 030 spools only.
 ‡ High Watt only.

Bold: Designates Tier I products and options.

Non-Bold: Designates Tier II products and options. These products will have longer lead times.

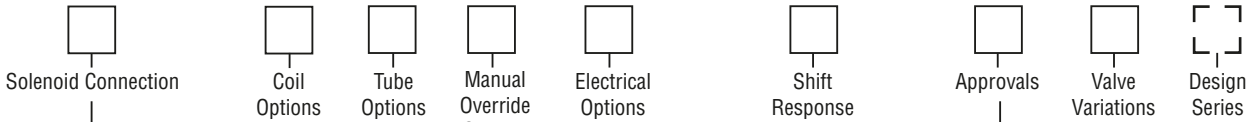

Code	Description
C*	Leadwire Conduit Box
D**	Metric Plug (M12X1), DESINA
E†	Explosion Proof
G††	Plug-In Conduit Box
J#	Deutsch (DT06-2S)
M#	Metri-Pack (150)
P	DIN with Plug
S#	Dual Spade
W†	DIN w/o Plug

* No variations – See Plug-in.
 ** DC only, lights, diode surge suppressor, not CSA approved.
 † Not available with lights.
 †† Required for variations on conduit box style. Must have lights.
 # DC only, no lights, not CSA approved.

Code	Description
Omit	Standard Response
S2*	Soft Shift, 0.020" Orifice
S3*	Soft Shift, 0.030" Orifice
S4*	Soft Shift, 0.040" Orifice
S5*	Soft Shift, 0.050" Orifice
17**	Monitor Switch Direct Op. End Stroke
18**	Monitor Switch Direct Op. Start Stroke

* Not available with 10 watt. AC DIN coil must include plug.
 ** Single solenoid models only. Not CE or CSA approved.

Code	Description
Omit*	High Watt
D**	Explosion Proof, EEXD ATEX
E**	Explosion Proof, EEXME ATEX
F†	Low Watt
L††	10 Watt
O**	Explosion Proof, MSHA
T#	Explosion Proof, Ex d IIC ATEX/CSA
U**	Explosion Proof, UL/CSA

* AC ambient temperature must not exceed 60°C (140°F).
 ** 60 Hz only on AC, no options.
 † AC only.
 †† DC and AC rectified only.
 # J, K and Y voltages only. Dual frequency on AC, no options.

Code	Description
Omit	No Options
J**	Diode Surge Suppressor
Z†	Rectified Coil

† DC tube standard.
 ** DC only. DIN coil must have plug with lights.

Code	Description
Omit	Standard Valve
3*†	CSA US
4*#	CSA Canada

* Not available with AC high pressure tube.
 † B, C, H styles only. J, K, Y, U voltages only. C, G, W sol. connections only. Conforms to UL429.
 # Valve is derated.

Code	Description
Omit	Standard
T*†	No Override
P*	Extended Manual Override w/Boot

* Manual override options not available on explosion proof or soft shift.
 † DC/AC rectified only.

Code	Description
Omit	Standard Pressure
	103.5 Bar (1500 PSI) AC
	207 Bar (3000 PSI) DC
H*	High Pressure, AC only
	207 Bar (3000 PSI)

* Not available with CSA.

Code	Description
Omit	No Variations
5**	Signal Lights
56*	Manplug (Mini) with Lights
7B*	Manplug (Micro) with Lights
1C*	Manplug (Mini) Single Sol. 5-pin, with Lights
1D*	Manplug (Micro) Single Sol. 5-pin, with Lights
1M*	Manplug Opposite of Normal
4D†	Twist & Lock Override (Old 5426, 33 Ford wiring)
4E†	Push Manual Override (Old x5450)
4F	Heavy Duty Detent
1P	Painted Body
7Y*	4-pin M12x1 Manplug, special wiring with lights (Old B755)

* Plug-in Conduit Box
 ** Plug-in, DIN, or DESINA only
 † DC/AC Rectified only. Not available with soft shift.

Valve Weight:
 Single Solenoid 1.36 kg (3.0 lbs.)
 Double Solenoid 1.6 kg (3.5 lbs.)
Standard Bolt Kit: BK209
Metric Bolt Kit: BKM209
Seal Kit:
 Nitrile SKD1VWN91
 Fluorocarbon SKD1VWV91

Bold: Designates Tier I products and options.

Non-Bold: Designates Tier II products and options. These products will have longer lead times.

Inch equivalents for millimeter dimensions are shown in (**)

A

DC Plug-In Conduit Box Connector, with Lights, Double Solenoid

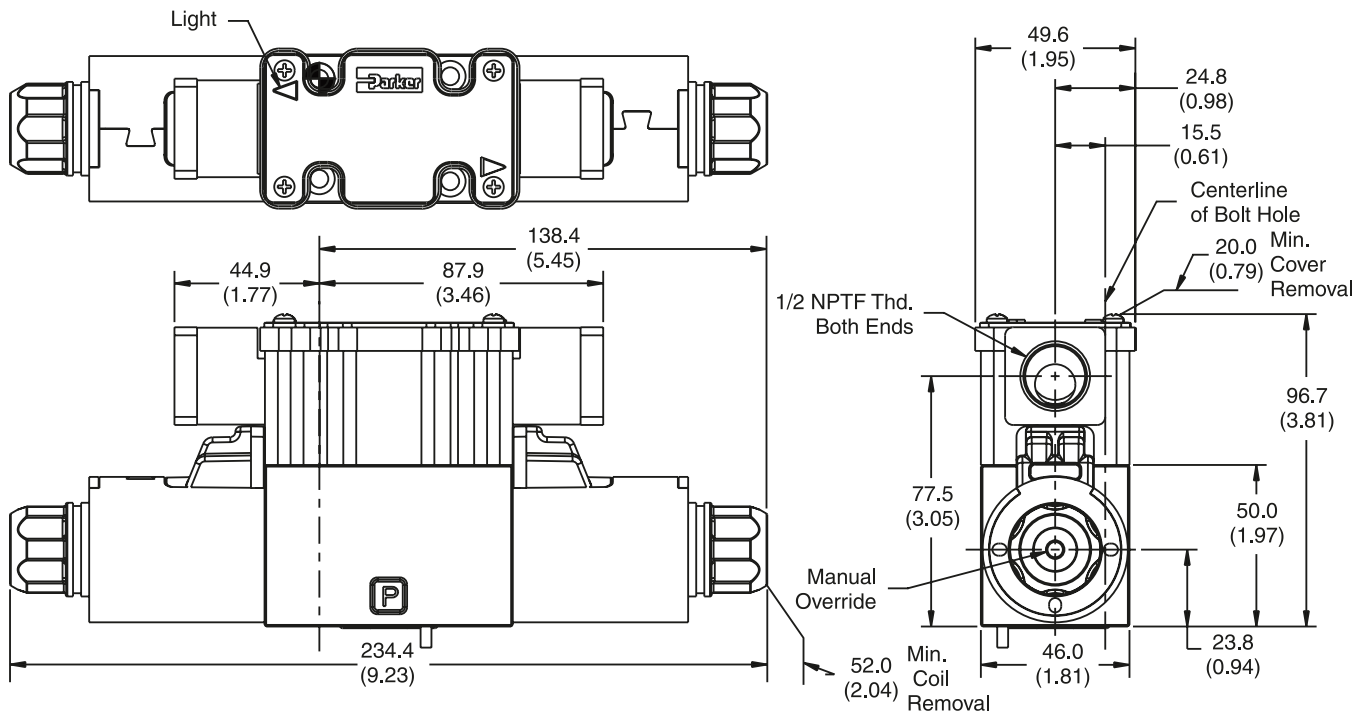

Note: 22.0 mm (0.87") from bottom of bolt hole counterbore to bottom of valve.

DC Plug-In or Leadwire Conduit Box Connector, with or without Lights, Single Solenoid

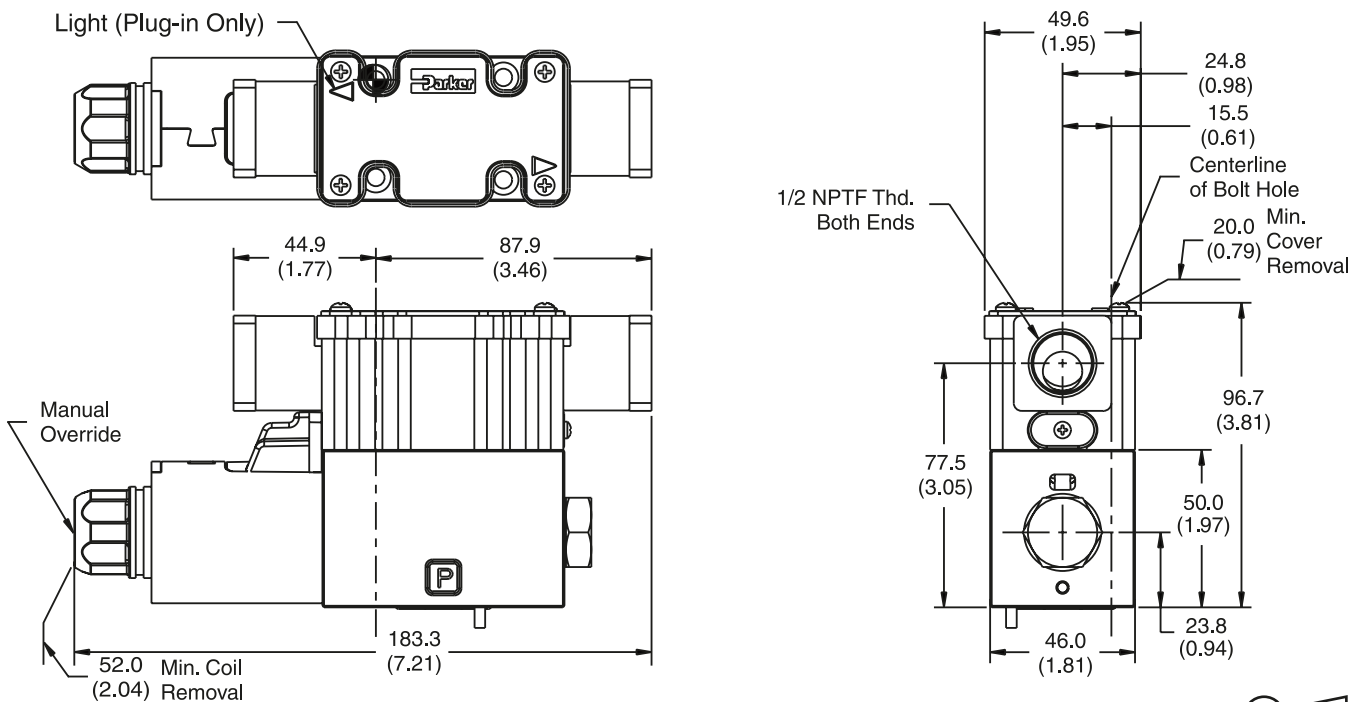

Note: 22.0 mm (0.87") from bottom of bolt hole counterbore to bottom of valve.

D1.indd, dd

Inch equivalents for millimeter dimensions are shown in (**)

DC DIN with Plug Connector, Double Solenoid
“P” Option Shown

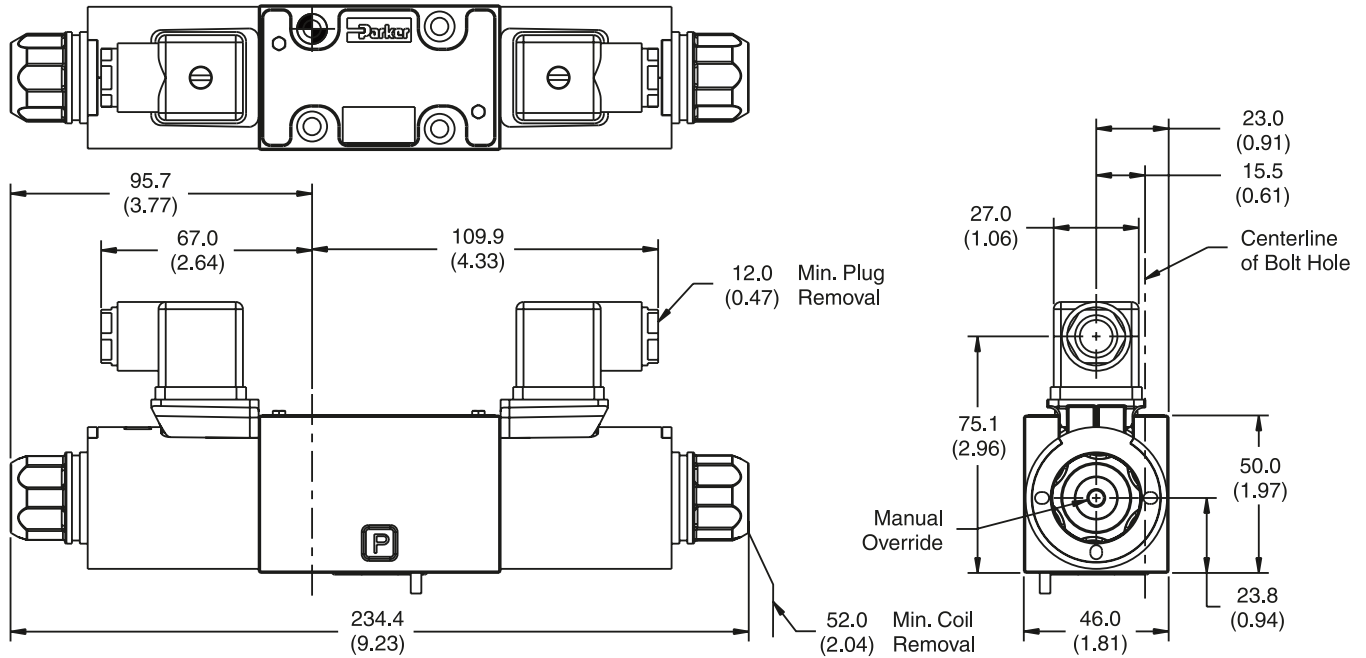

Note: 22.0 mm (0.87") from bottom of bolt hole counterbore to bottom of valve.

DC DIN Connector, Single Solenoid
“P” Option Shown

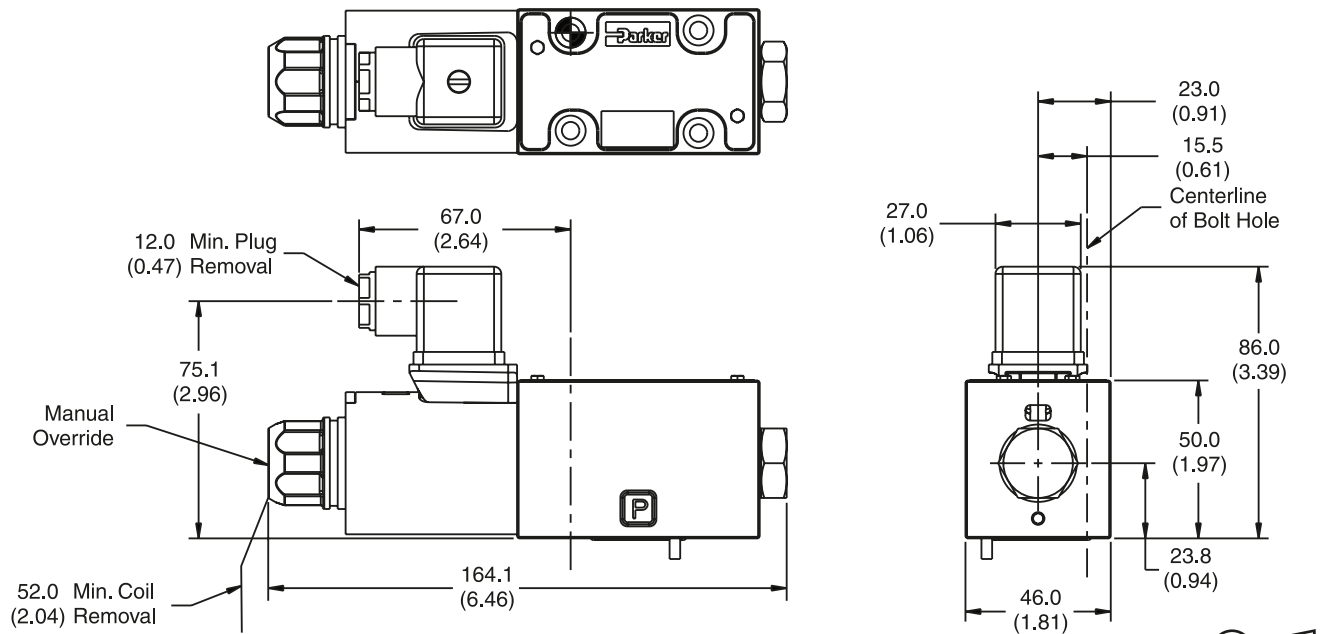

Note: 22.0 mm (0.87") from bottom of bolt hole counterbore to bottom of valve.

Inch equivalents for millimeter dimensions are shown in (**)

A

AC Leadwire Conduit Box Connector, without Lights, Double Solenoid, "C" Option

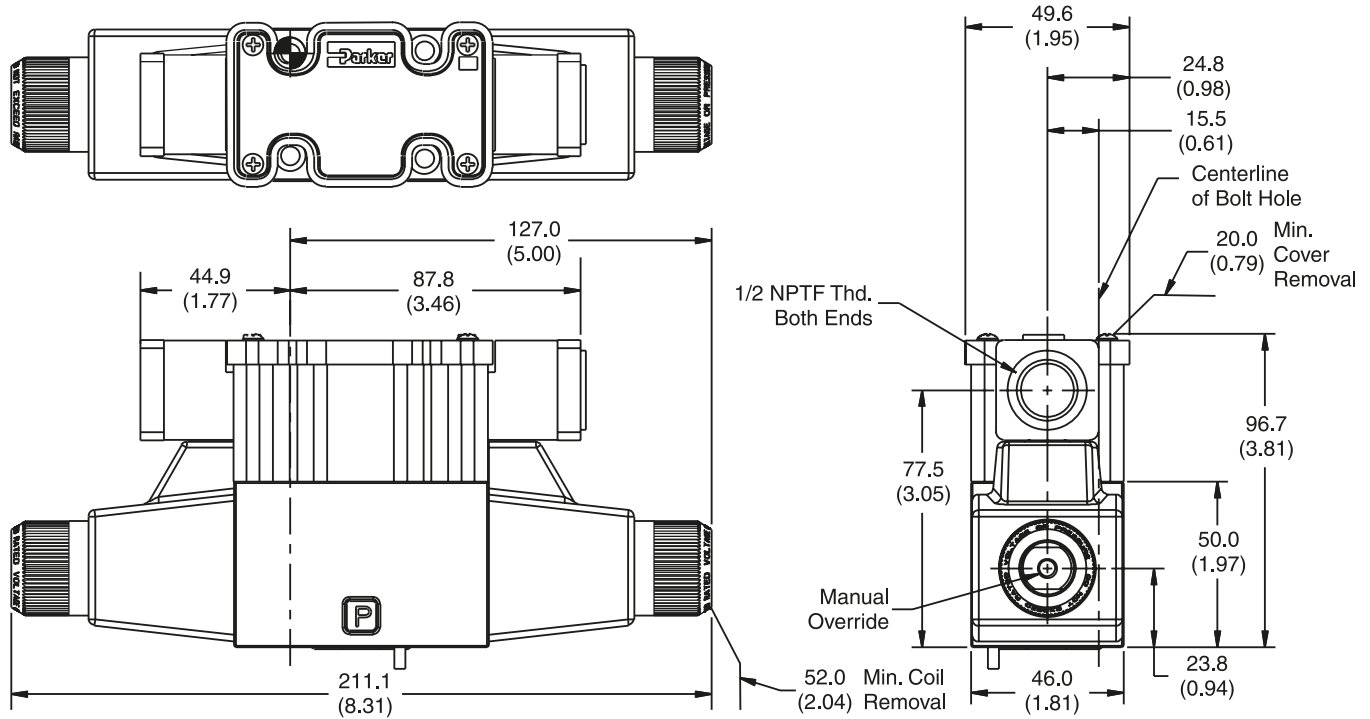

Note: 22.0 mm (0.87") from bottom of bolt hole counterbore to bottom of valve.

AC Leadwire Conduit Box Connector, without Lights, Single Solenoid, "C" Option

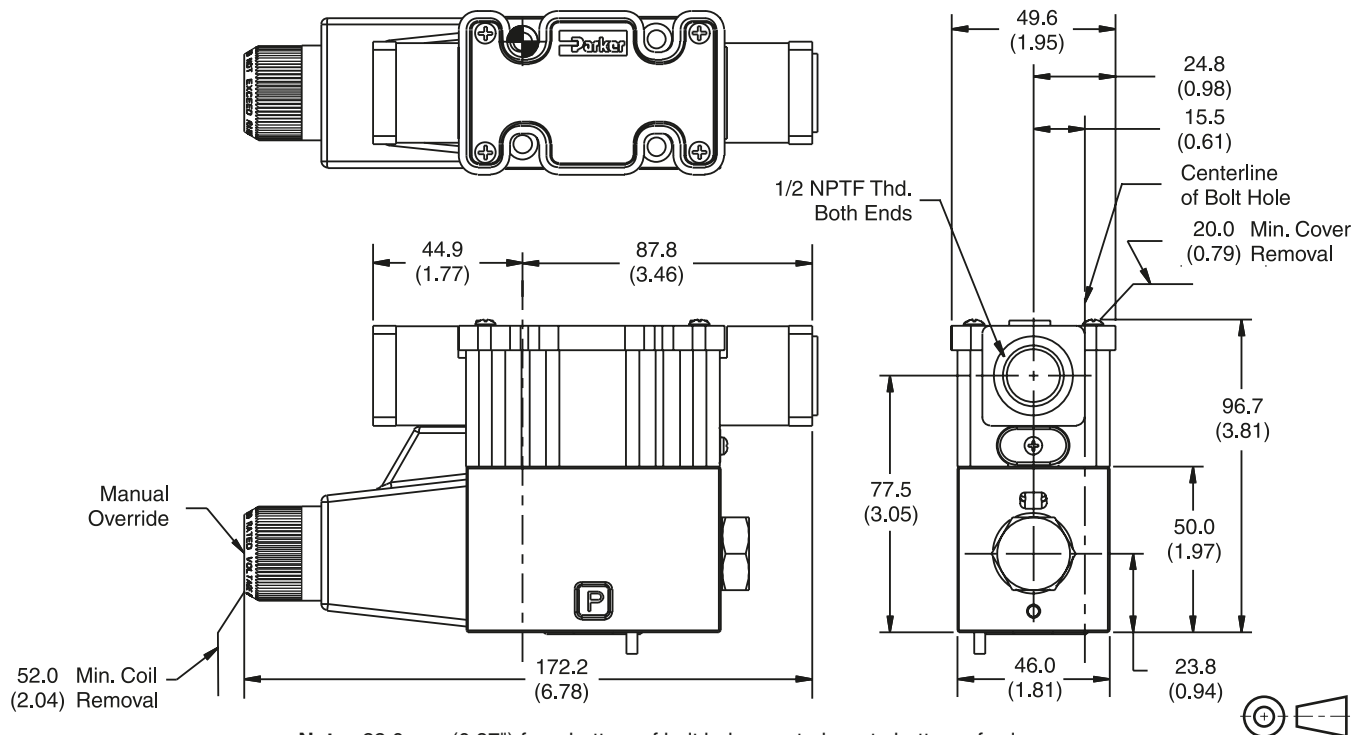

Note: 22.0 mm (0.87") from bottom of bolt hole counterbore to bottom of valve.

Inch equivalents for millimeter dimensions are shown in (**)

AC Plug-in Conduit Box Connector, with Lights, Double Solenoid, "G" Option

A

Light (Plug-in Only)

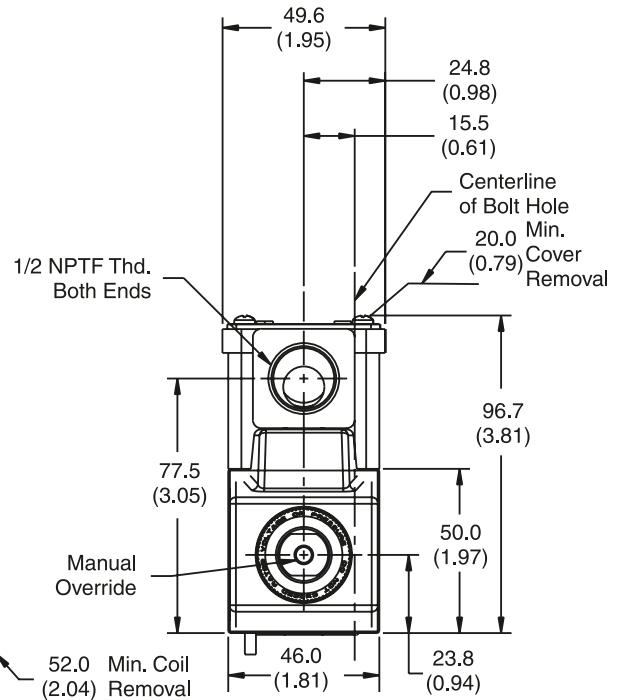
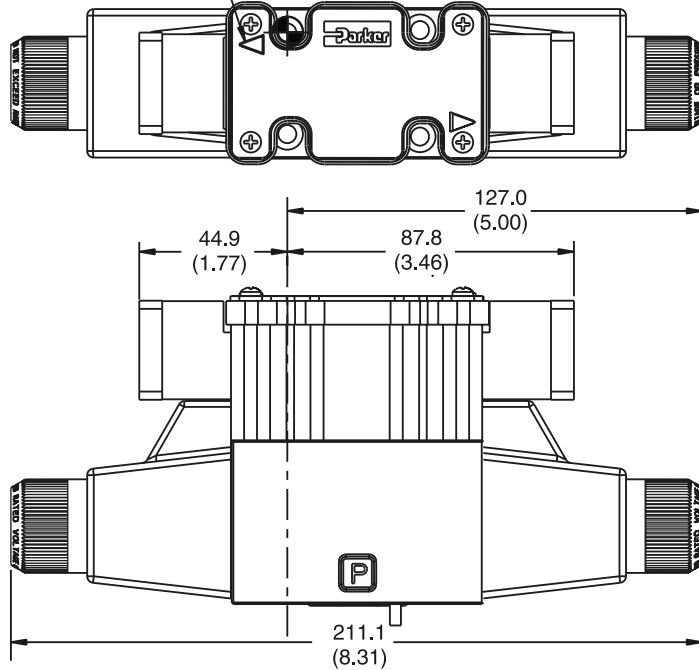

Note: 22.0 mm (0.87") from bottom of bolt hole counterbore to bottom of valve.

DC Plug-in or Leadwire Conduit Box Connector, with or without Lights and Extended Override Tubes, Double Solenoid

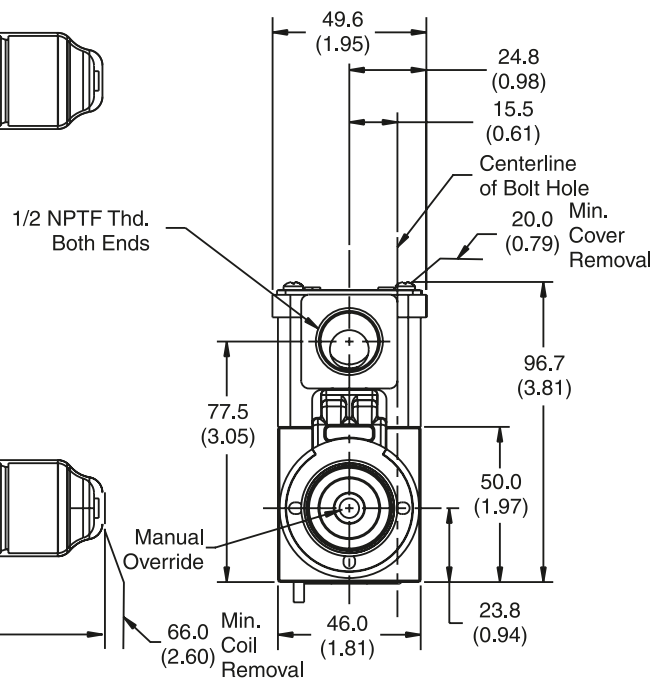
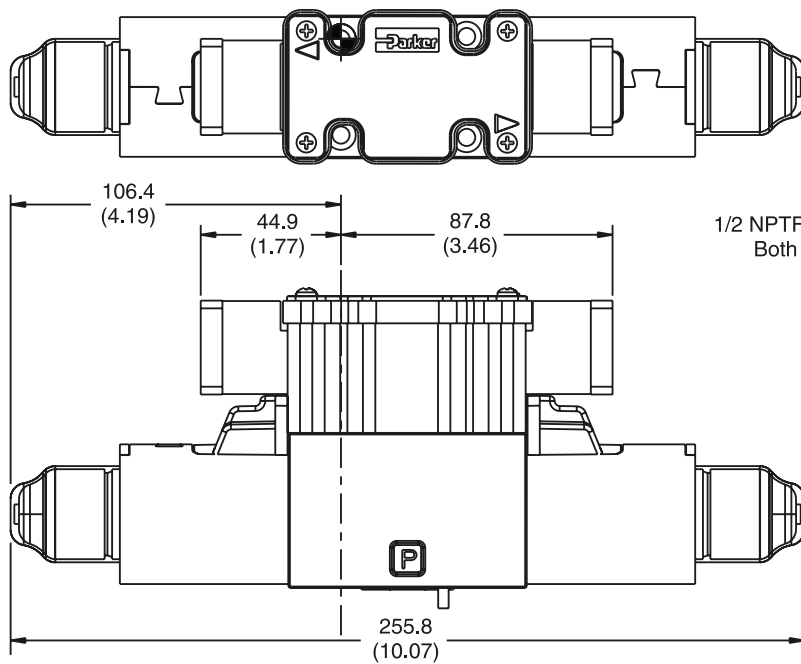

Note: 22.0 mm (0.87") from bottom of bolt hole counterbore to bottom of valve.



Inch equivalents for millimeter dimensions are shown in (**)

A

DC Deutsch Connector, Double Solenoid

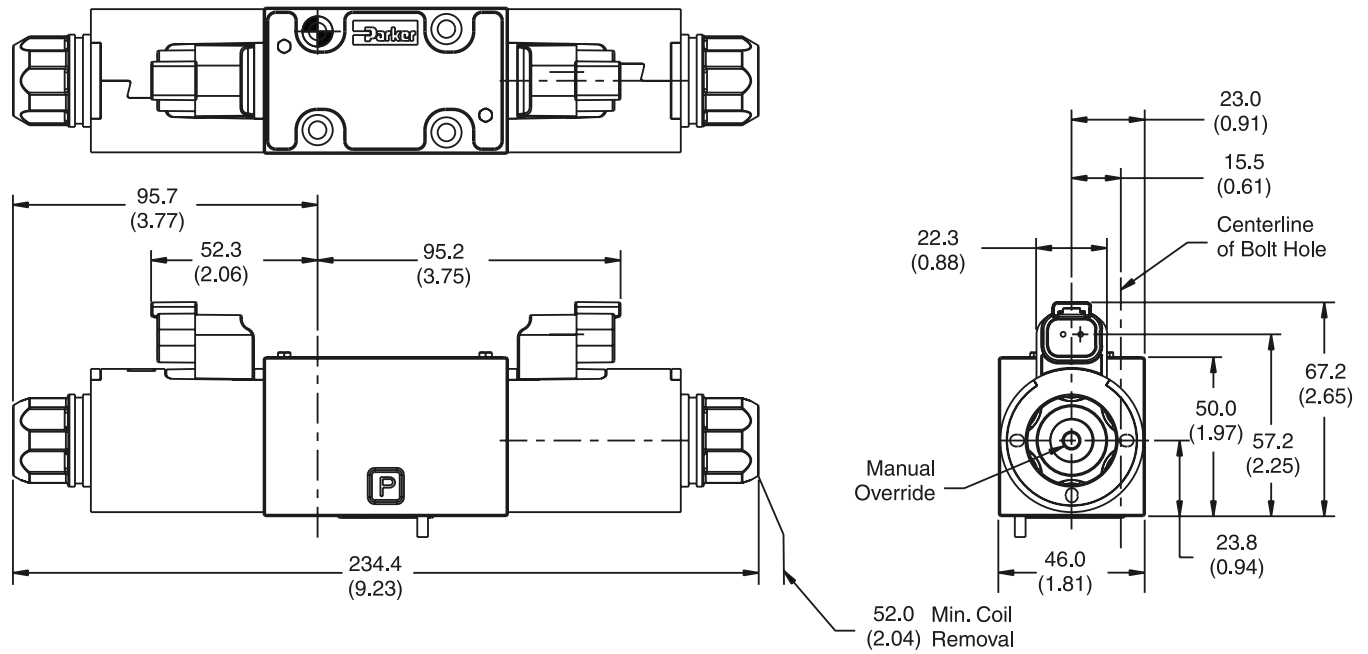

Note: 22.0 mm (0.87") from bottom of bolt hole counterbore to bottom of valve.

DC Deutsch Connector, Single Solenoid

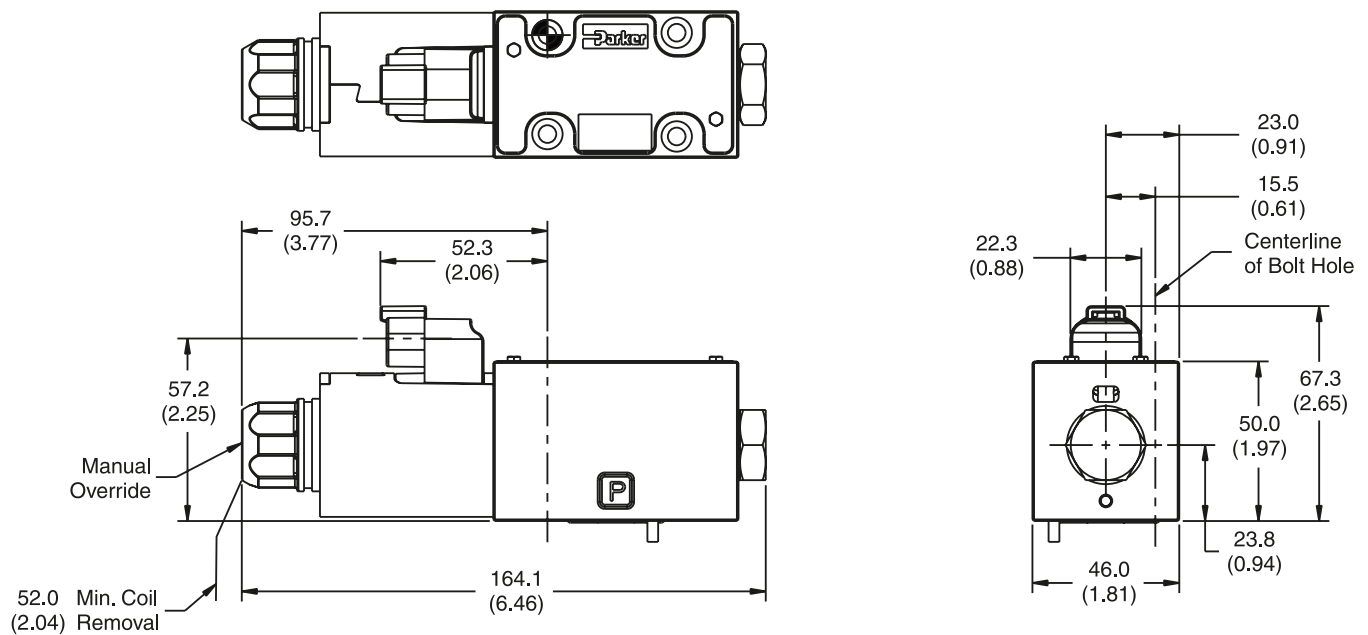

Note: 22.0 mm (0.87") from bottom of bolt hole counterbore to bottom of valve.

Inch equivalents for millimeter dimensions are shown in (**)

DC Desina Connector, Double Solenoid

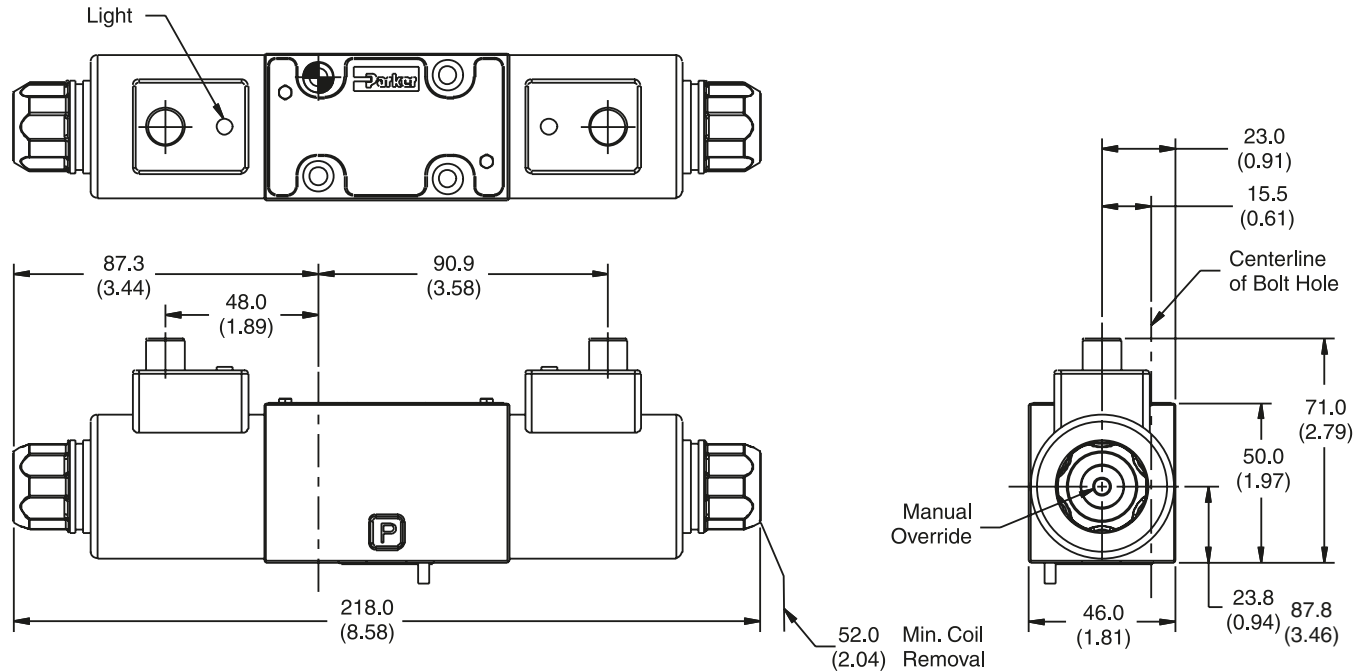

Note: 22.0 mm (0.87") from bottom of bolt hole counterbore to bottom of valve.

DC Desina Connector, Single Solenoid

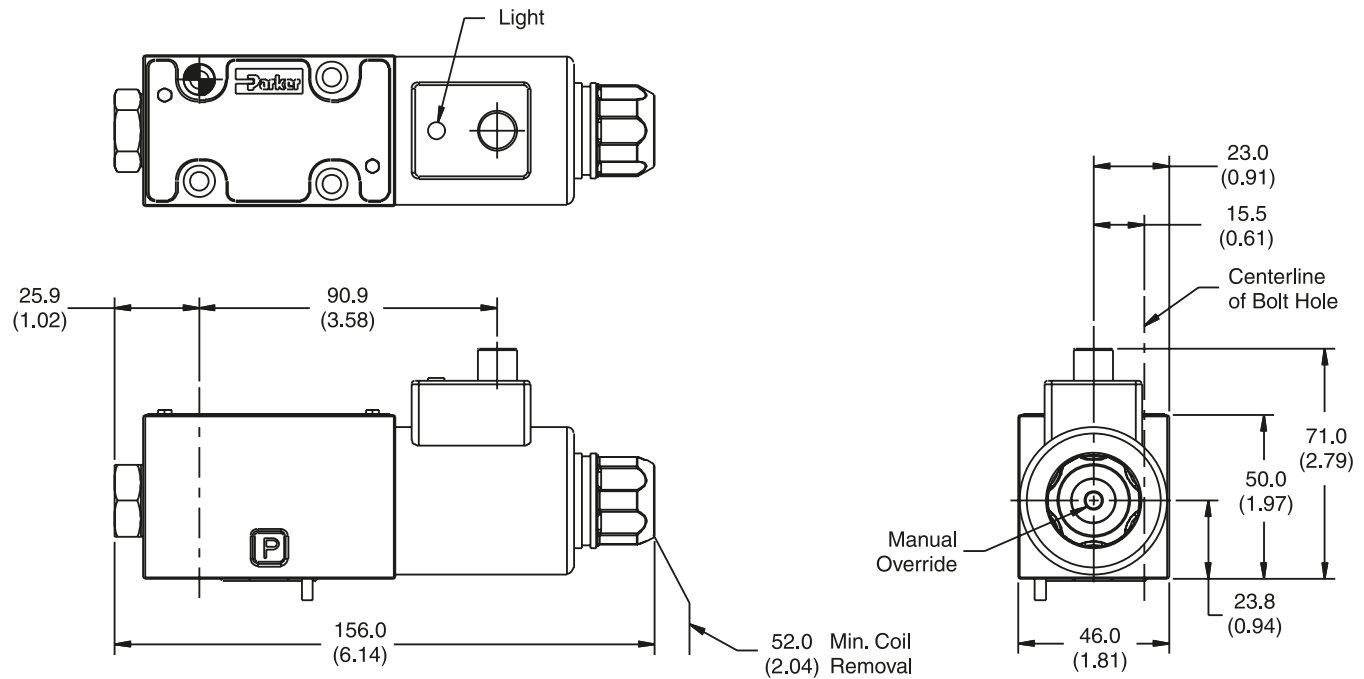

Note: 22.0 mm (0.87") from bottom of bolt hole counterbore to bottom of valve.

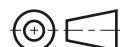

Inch equivalents for millimeter dimensions are shown in (**)

Explosion Proof U.L. & C.S.A., Double Solenoid

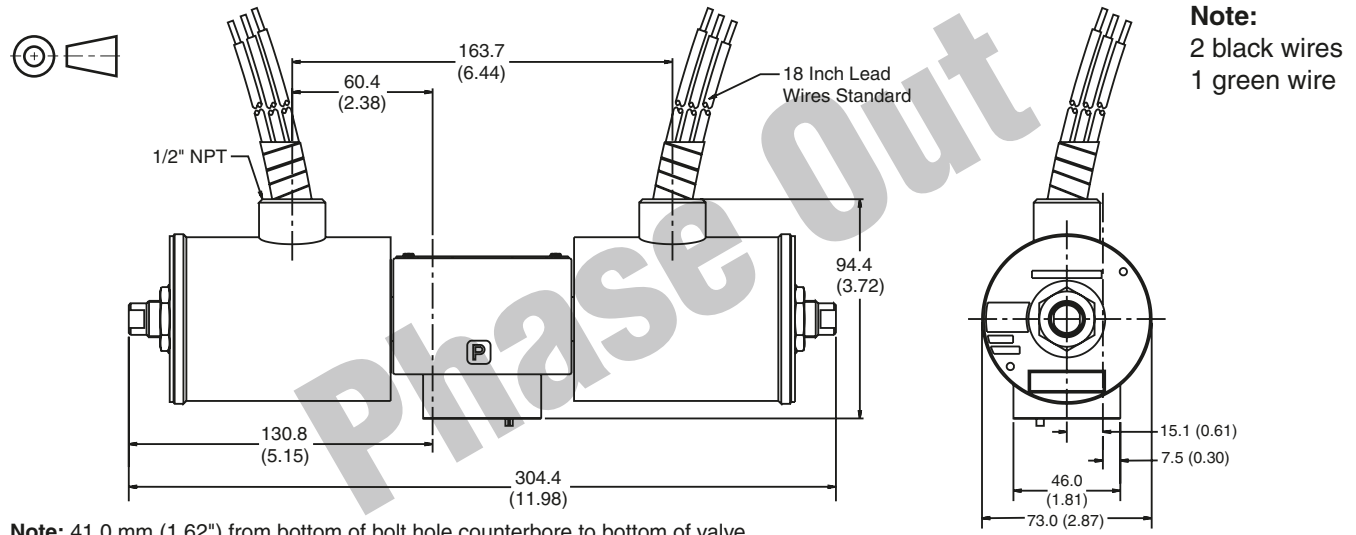

Note: 41.0 mm (1.62") from bottom of bolt hole counterbore to bottom of valve.

Explosion Proof M.S.H.A., Double Solenoid

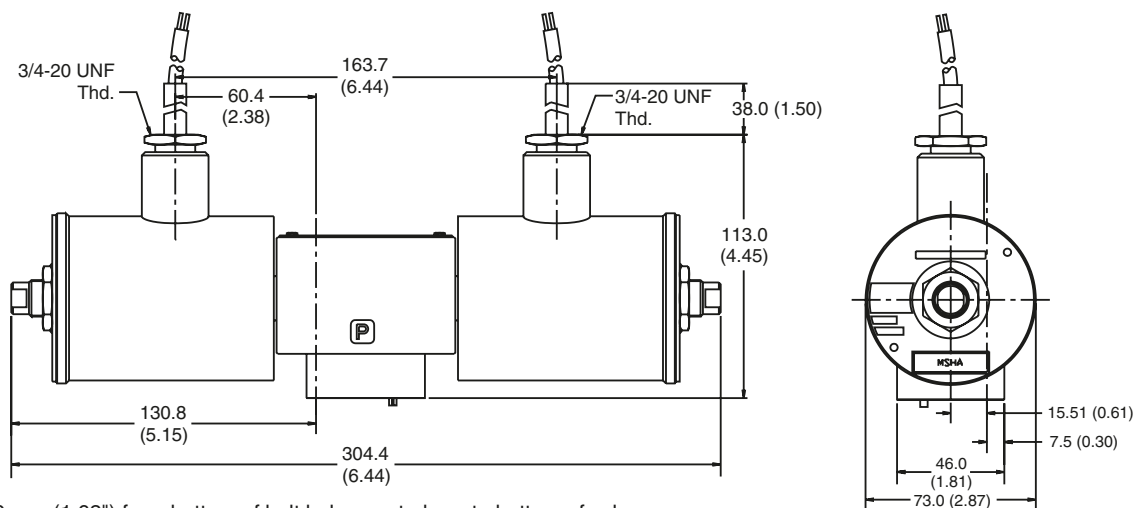

Note: 41.0 mm (1.62") from bottom of bolt hole counterbore to bottom of valve.

Explosion Proof, EEXD ATEX, Double Solenoid

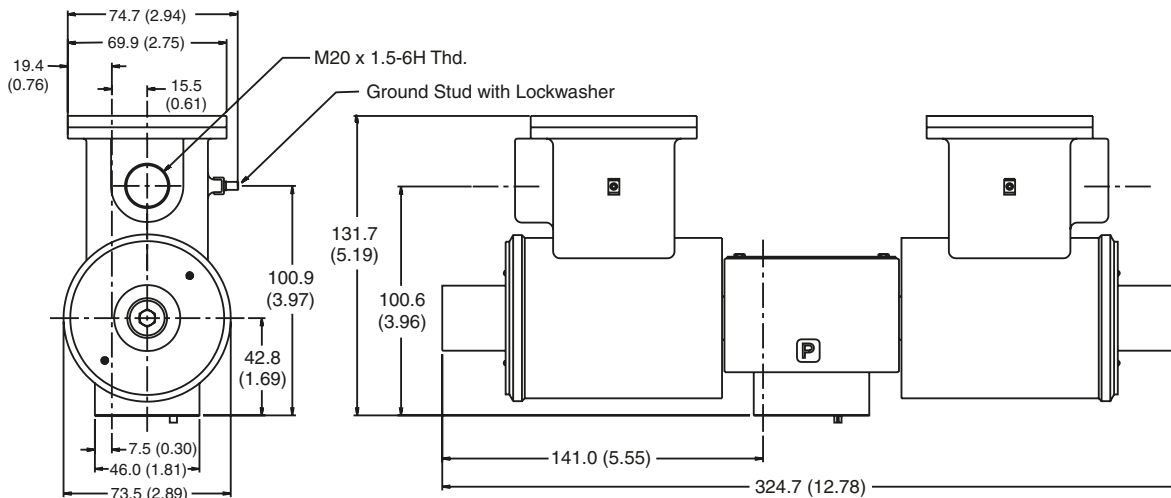

D1.indd, dd

Inch equivalents for millimeter dimensions are shown in (**)

A

DC Plug-in or Leadwire Conduit Box with Monitor Switch, with or without Lights, Single Solenoid

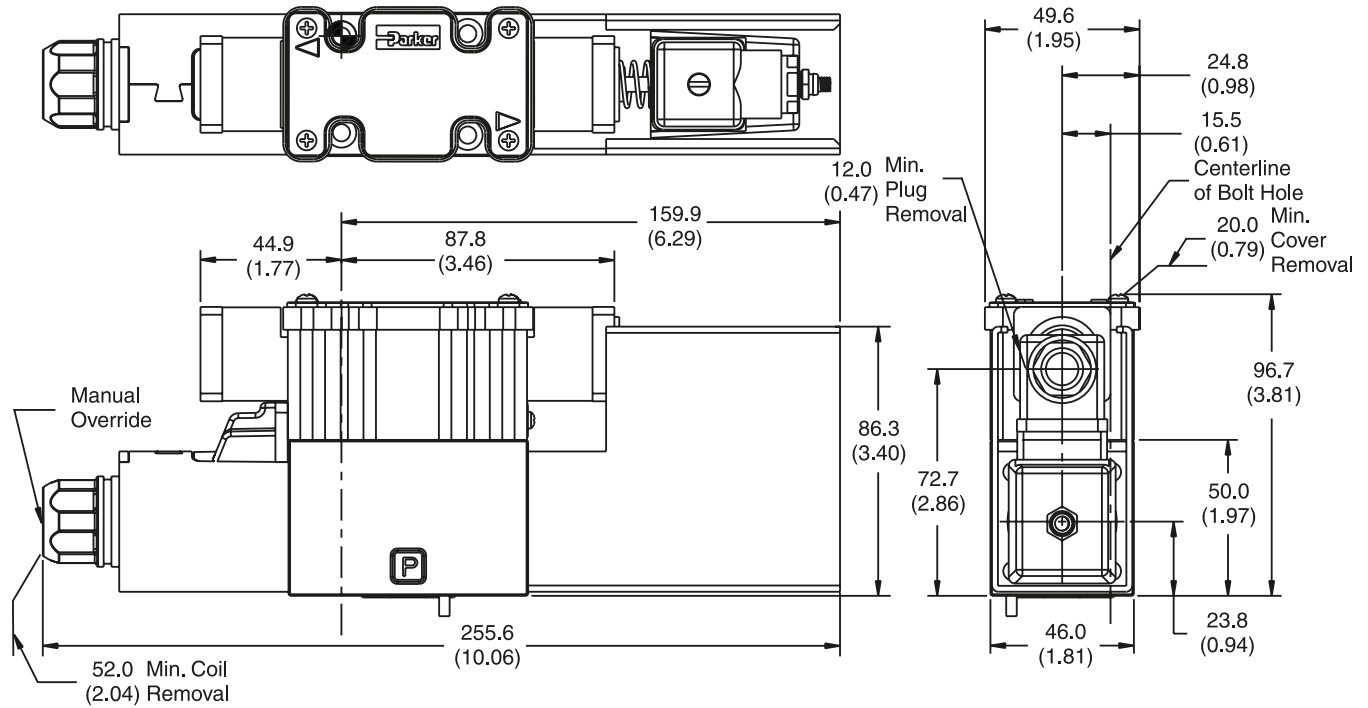

Note: 22.0 mm (0.87") from bottom of bolt hole counterbore to bottom of valve.



Monitor Switch

(Variation I7 and I8)

This feature provides for electrical confirmation of the spool shift. This can be used in safety circuits, to assure proper sequencing, etc.

Switch Data

Inductive switch requiring +18-42 volt input. Outputs "A" and "B" are opposite; one at "0" voltage, the other at input voltage. During switching, "A" and "B" outputs reverse. Provides 0.4A switching current.

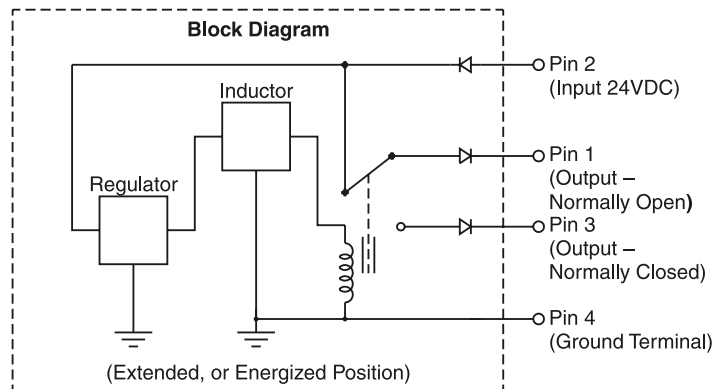

For repetitive switch power-up conditions, please consult factory.



Manaplug (Options 56 & 1C)

- Interface – Brad Harrison Plug
 – 3-Pin for Single Solenoid
 – 5-Pin for Double Solenoid

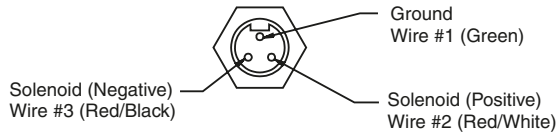

3-Pin Manaplug (Mini) with Lights

Single Solenoid Valves – Installed Opposite Side of Solenoid

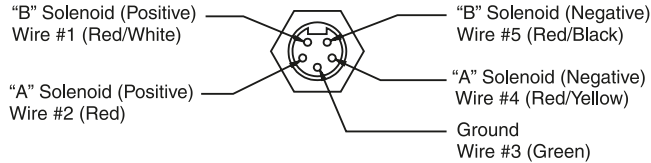

5-Pin Manaplug (Mini) with Lights

Single Solenoid Valves – Installed Opposite Side of Solenoid
 Double Solenoid Valves – Installed Over "A" Solenoid
 ("A" and "B" Solenoids Reversed for #8 and #9 Spools)

Micro Connector Options (7B & 1D)

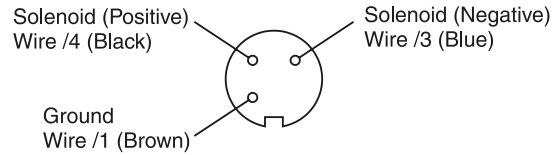

3-Pin Manaplug (Micro) with Lights

Single Solenoid Valves – Installed Opposite Side of Solenoid

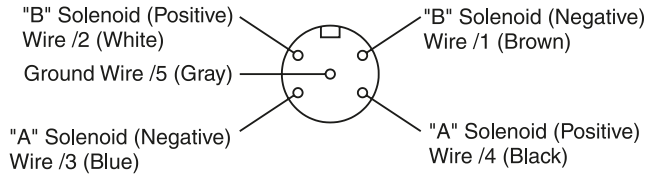

5-Pin Manaplug (Micro) with Lights

Single Solenoid Valves – Installed Opposite Side of Solenoid
 Double Solenoid Valves – Installed Over "A" Solenoid
 ("A" and "B" Solenoids Reversed for #8 and #9 Spools)

Pins are as seen on valve (male pin connectors)

Conduit Box Option C

- No Wiring Options Available

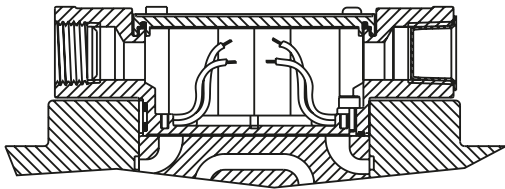

Signal Lights (Option 5) — Plug-in Only

- LED Interface
 – Meets Nema 4/IP67

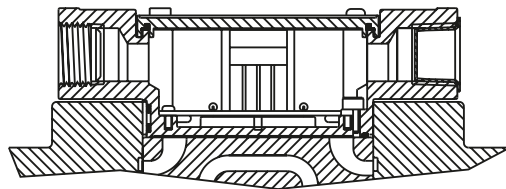

Hirschmann Plug with Lights (Option P5)

ISO 4400/DIN 43650 Form "A"

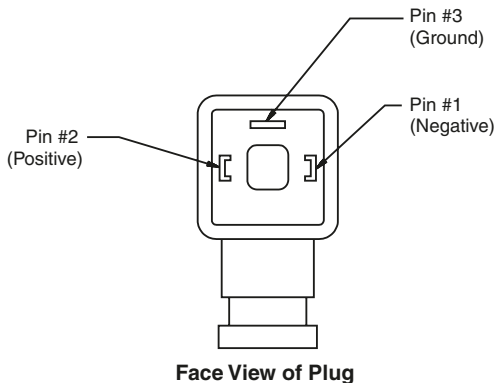

Pins are as seen on valve (male pin connectors)

DESINA Connector (Option D)

M12 pin assignment
Standard

- 1 = Not used
- 2 = Not used
- 3 = 0V
- 4 = Signal (24 V)
- 5 = Earth Ground

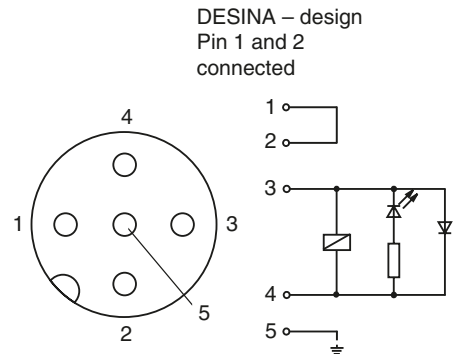

Mounting Bolt Kits

A

Bolt Kits for use with D1V Directional Control Valves, "ET" Explosion Proof & Sandwich Valves (D1V*-91, 82 & 70/75 Design, Solenoid Operated & D1V*-72 Design, Non-Solenoid Operated)

		Number of Sandwich Valves @40mm (1.58") thickness									
		0		1		2		3		4	
Number of Sandwich Valves at 44.5mm (1.75") Thickness	0	BK209	1.25 in.	BK243	2.88 in.	BK225	4.38 in.	BK244	6.00 in.	BK245	7.50 in.
		BKM209	30 mm	BKM243	70 mm	BKM225	110 mm	BKM244	150 mm	BKM245	190 mm
	1	BK246	3.00 in.	BK247	4.62 in.	BK248	6.12 in.	BK249	7.75 in.		
		BKM246	75 mm	BKM247	115 mm	BKM248	155 mm	BKM249	195 mm		
	2	BK250	4.75 in.	BK251	6.38 in.	BK252	7.88 in.				
		BKM250	120 mm	BKM251	160 mm	BKM252	200 mm				
	3	BK253	6.50 in.	BK254	8.12 in.						
		BKM102	170 mm	BKM254	205 mm						
	4	BK103	8.25 in.								
		BKM103	210 mm								

Note: All bolts are SAE Grade 8, 10-24 UNC 2A thread (Metric-M5-0.8)
 Torque to 5.6 Nm (50 in-Lb).

Bolt Kits for use with D1V Directional Control Valves with Explosion Proof Coils & Sandwich Valves (D1V*-91, 82 & 70/75 Design) Except "ET" Coil

		Number of Sandwich Valves @40mm (1.58") thickness									
		0		1		2		3		4	
Number of Sandwich Valves at 44.5mm (1.75") Thickness	0	BK50	2.00 in.	BK211	3.63 in.	BK101	5.12 in.	BK102	6.75 in.	BK103	8.25 in.
		BKM50	50 mm	—	BKM101	130 mm	BKM102	170 mm	BKM103	210 mm	
	1	BK51	3.75 in.	BK212	5.37 in.	BK105	6.87 in.	BK106	7.75 in.		
		BKM51	95 mm	—	BKM105	180 mm	BKM106	195 mm			
	2	BK52	5.50 in.	BK213	7.13 in.	BK108	8.62 in.				
		BKM52	140 mm	—	BKM108	220 mm					
	3	BK53	7.25 in.	BK214	8.87 in.						
		BKM53	185 mm	—							
	4	BK54	9.00 in.								
		BKM54	230 mm								

Note: All bolts are SAE Grade 8, 10-24 UNC 2A thread (Metric-M5-0.8)
 Torque to 5.6 Nm (50 in-Lb).

Sandwich Valve Dimensional Data

All D03 Sandwich valves (starting with 31 Series) including CM2, CPOM2, FM2, PRDM2 and RM2 measure 40mm (1.58") thickness.

For additional technical information about Sandwich valves, refer to the Sandwich Valve Section of this Catalog.

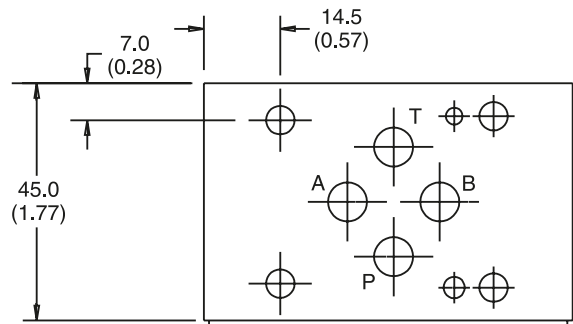

General Description

Series D1VA and D1VP directional control valves are high performance, 4 and 5-chamber, direct operated, air and oil pilot controlled, 3 or 4-way valves. They are available in 2 or 3-position and conform to NFPA's D03, CETOP 3 mounting patterns.

Features

- Low pilot pressure required.
 D1VA – 4.1 Bar (60 PSI) minimum
 D1VP – 15.2 Bar (220 PSI) minimum

Air Operated

Shift Volume. The air pilot chamber requires a volume of 1.8 cc (.106 in.³) for complete shift from center to end.

Pilot Piston. The pilot piston area is 506 mm² (.785 in.²). Pilot piston stroke is 3.4 mm (.135 in.).

Response Time. Response time will vary with pilot line size, pilot line length, pilot pressure, air control valve shift time and air valve flow capacity (Cv).

Oil Operated

Shift Volume. The hydraulic pilot chamber requires a volume of 0.7 cc (.042 in.³) for complete shift from center to end.

Pilot Piston. The hydraulic piston area is 198 mm² (.307 in.²). Pilot piston stroke is 3.4 mm (.135 in.).

Response Time. Response time will vary with pilot line size, pilot line length, pilot pressure, pilot valve shift time and oil valve flow capacity (GPM).

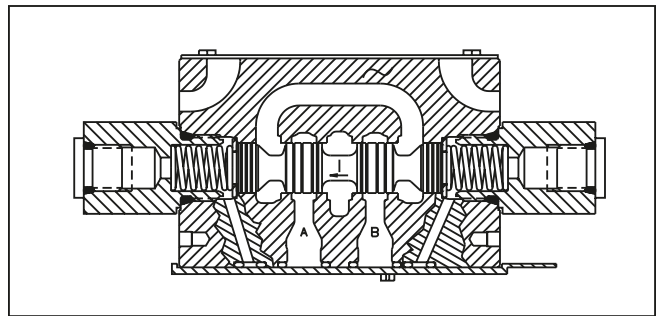
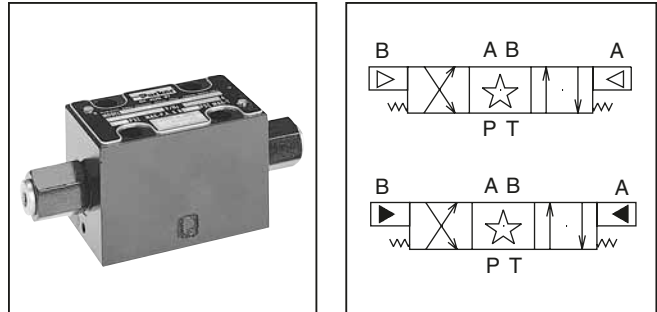

Specifications

Mounting Pattern	NFPA D03, CETOP 3, NG 6
Maximum Pressure	Operating: 345 Bar (5000 PSI) Tank Line: D1VA 34 Bar (500 PSI) D1VP 207 Bar (3000 PSI)
Maximum Flow	See Reference Data
Pilot Pressure	D1VA: Air Minimum 4.1 Bar (60 PSI) Air Maximum 10.2 Bar (150 PSI) D1VP: Oil Minimum 15.2 Bar (220 PSI) Oil Maximum 207 Bar (3000 PSI)

Dimensions – Inch equivalents for millimeter dimensions are shown in (**)

Oil Operated D1VP, Single and Double Pilot

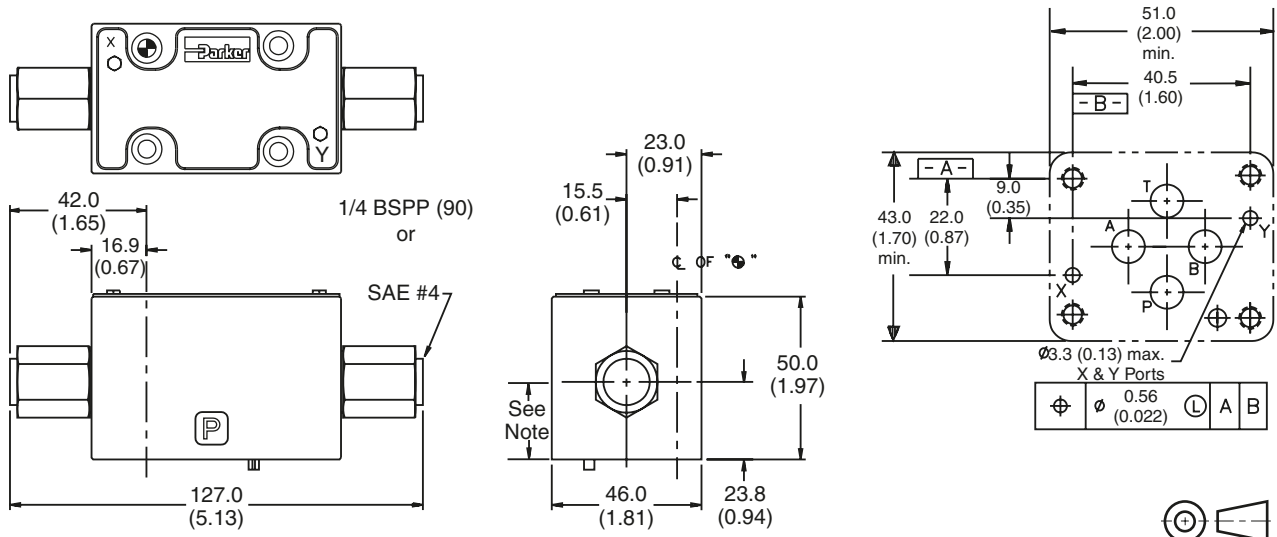

Note: 22.0 mm (0.87") from bottom of bolt hole counterbore to bottom of valve.



A

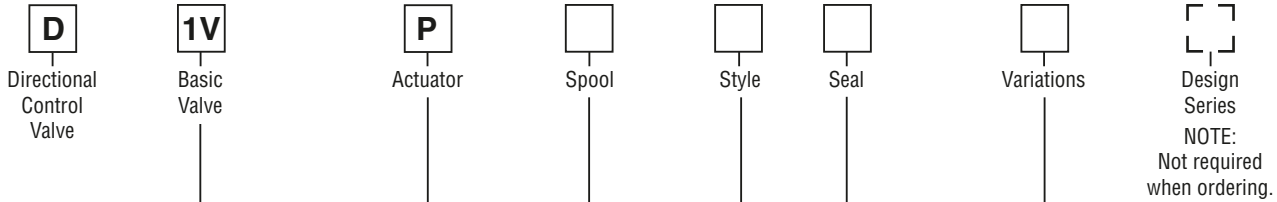

NFPA D03
 CETOP 3

Oil
 Operator

Code	Description
Omit	Standard
P10*	Monitor Switch
4F	Heavy Duty Detent
90	BSPB Threads

* Not available on C and D styles.
 Not CE or CSA approved.

Code	Description
N	Nitrile
V	Fluorocarbon

Code	Symbol
001	
002	
004	
008*	
009**	
020*	
026*	
030**	
081	
082	

Code	Description	Symbol
B#	Single operator, two position spring offset. P to A and B to T in offset position.	
C	Double operator, three position, spring centered.	
D	Double operator, two position, detent.	
E#	Two position, spring centered. P to B and A to T in shifted position.	
H#	Single operator, two position, spring offset. P to B and A to T in offset position.	
K#	Two position, spring centered. P to A and B to T in shifted position.	

D available with 020 and 030 spools only.
 B & H available with 020, 026 and 030 spools only.
 E & K not available with 020, 026 and 030 spools.

This condition varies with spool code.

Valve schematic symbols are per NFPA/ANSI standards, providing flow P to A when energizing operator X. Note operators reverse sides for #008 and #009 spools. See installation information for details.

* 008, 020 and 026 spools have closed crossover.
 ** 009 and 030 spools have open crossover.

Valve Weight: 1.90 kg (4.2 lbs.)
Standard Bolt Kit: BK209 10–24x1.25
Metric Bolt Kit: BKM209 M5–0.8x30mm
Seal Kit:
 Nitrile SKD1VP
 Fluorocarbon SKD1VPV

Bold: Designates Tier I products and options.

Non-Bold: Designates Tier II products and options. These products will have longer lead times.

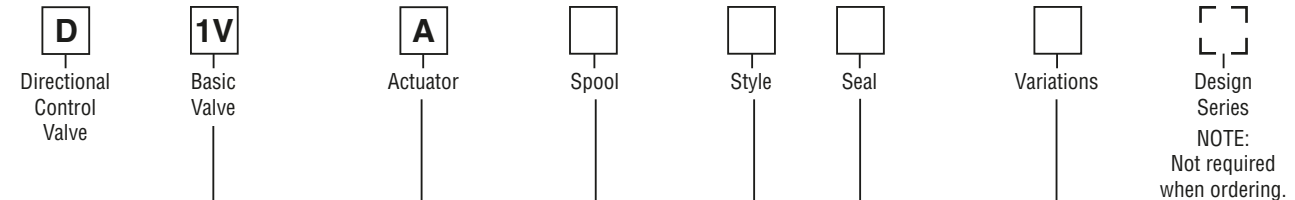

NFPA D03
CETOP 3

Air
Operator

Code	Description
Omit	Standard
P10*	Monitor Switch
90	1/4 BSPP Threads

* Not available on C & D styles.
 Not CE or CSA approved.

Code	Description
N	Nitrile
V	Fluorocarbon

Code	Symbol
001	
002	
004	
008*	
009**	
081	
082	

* 008 spool has closed crossover.
 ** 009 spool has open crossover.

Code	Description	Symbol
B	Single operator, two position spring offset. P to A and B to T in offset position.	
C	Double operator, three position, spring centered.	
D	Double operator, two position, detent.	
E	Two position, spring centered. P to B and A to T in shifted position.	
H	Single operator, two position, spring offset. P to B and A to T in offset position.	
K	Two position, spring centered. P to A and B to T in shifted position.	

Valve schematic symbols are per NFPA/ANSI standards, providing flow P to A when energizing operator A. Note operators reverse sides for #008 and #009 spools. See installation information for details.

This condition varies with spool code.

- Valve Weight:** 1.60 kg (3.5 lbs.)
- Standard Bolt Kit:** BK209 10–24x1.25
- Metric Bolt Kit:** BKM209 M5–0.8x30mm
Grade 8 bolts required
- Seal Kit:**
 - Nitrile SKD1VA
 - Fluorocarbon SKD1VAV

Bold: Designates Tier I products and options.

Non-Bold: Designates Tier II products and options. These products will have longer lead times.



Inch equivalents for millimeter dimensions are shown in (**)

A

Air Operated D1VA, Double Pilot

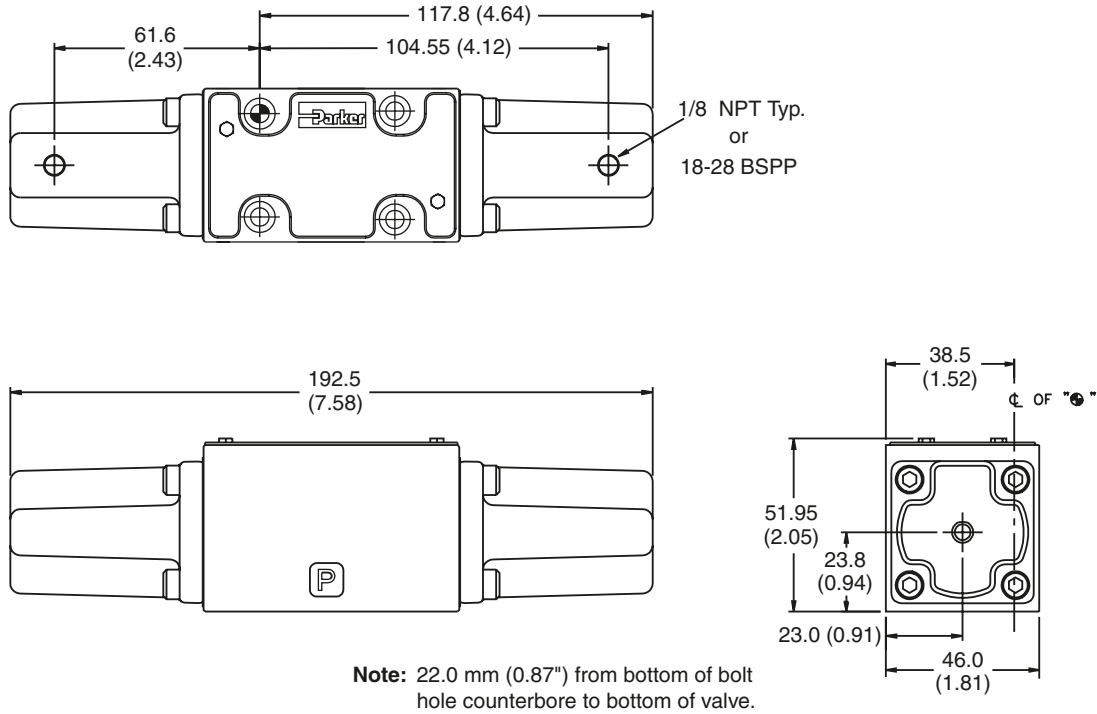

Air Operated D1VA, Single Pilot

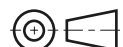
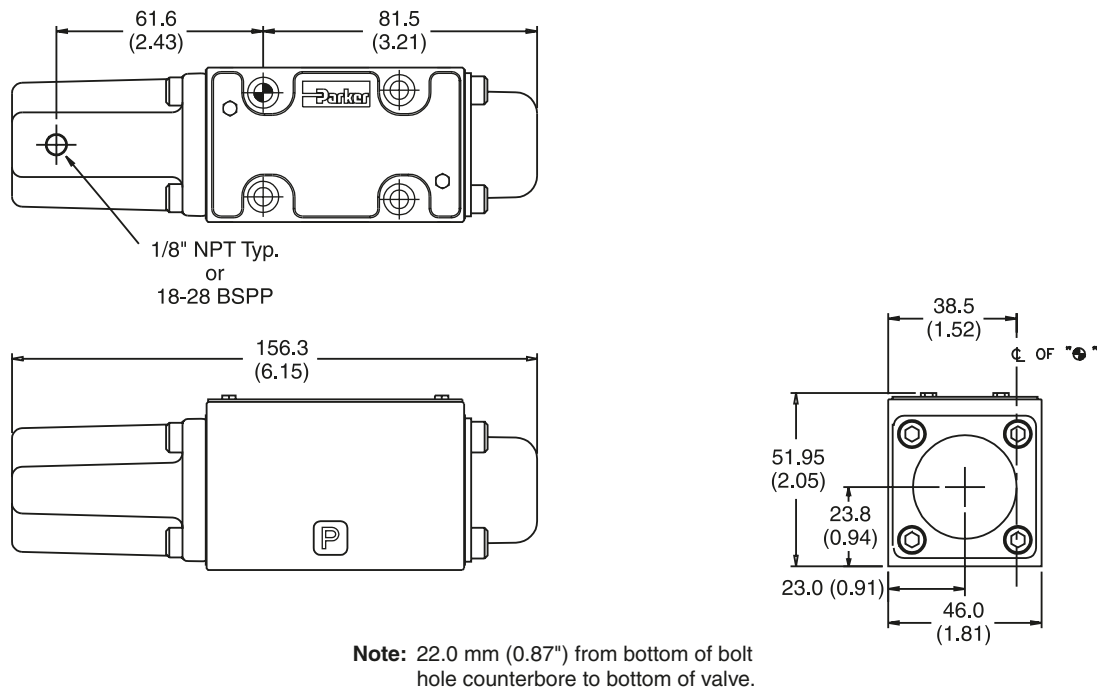

General Description

Series D1VC, D1VD and D1VG directional control valves are high performance, 4-chamber, direct operated, cam controlled, 4-way valves. They are available in 2-position and conform to NFPA's D03, CETOP 3 mounting patterns.

Features

- Choice of 2 cam roller positions (D1VC and D1VD)
- Two styles available (D1VC and D1VG)
- Short stroke option

Specifications

Mounting Pattern	NFPA D03, CETOP 3, NG 6
Maximum Pressure	Operating: 345 Bar (5000 PSI) Tank Line: 34 Bar (500 PSI)
Nominal Flow	32 LPM (8.5 GPM)
Maximum Flow	See Reference Data
Force Required to Shift	D1VC, D1VD: 107 N (24 lbs.) D1VG: 36 N (8 lbs.)
Maximum Cam Angle	30°

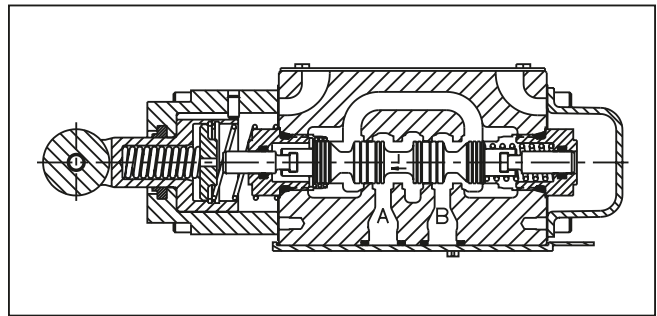
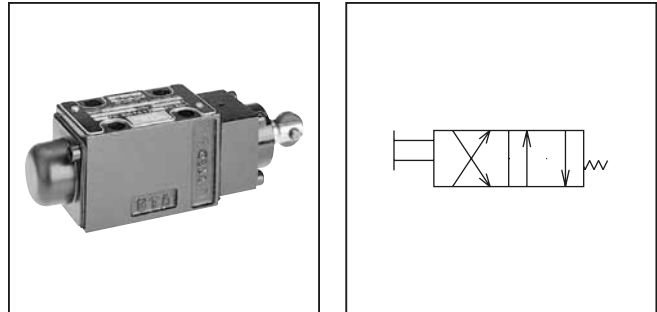

Ordering Information

<div style="border: 1px solid black; padding: 2px; width: 20px; margin: 0 auto;">D</div> Directional Control Valve	<div style="border: 1px solid black; padding: 2px; width: 20px; margin: 0 auto;">1V</div> Basic Valve <div style="border: 1px solid black; padding: 2px; width: 100px; margin: 5px auto; text-align: center;">NFPA D03 CETOP 3</div>	<div style="border: 1px solid black; width: 20px; height: 20px; margin: 0 auto;"></div> Actuator	<div style="border: 1px solid black; width: 20px; height: 20px; margin: 0 auto;"></div> Spool	<div style="border: 1px solid black; width: 20px; height: 20px; margin: 0 auto;"></div> Style	<div style="border: 1px solid black; width: 20px; height: 20px; margin: 0 auto;"></div> Seal	<div style="border: 1px solid black; width: 20px; height: 20px; margin: 0 auto;"></div> Variations	<div style="border: 1px dashed black; width: 20px; height: 20px; margin: 0 auto;"></div> Design Series NOTE: Not required when ordering.
--	---	--	---	---	--	--	--

<table border="1"> <thead> <tr> <th>Code</th> <th>Description</th> </tr> </thead> <tbody> <tr> <td>C</td> <td>Cam (90° to mounting surface)</td> </tr> <tr> <td>D</td> <td>Cam parallel to mounting surface</td> </tr> <tr> <td>G</td> <td>Cam Lever</td> </tr> </tbody> </table>	Code	Description	C	Cam (90° to mounting surface)	D	Cam parallel to mounting surface	G	Cam Lever	<table border="1"> <thead> <tr> <th>Code</th> <th>Symbol</th> </tr> </thead> <tbody> <tr> <td>001</td> <td></td> </tr> <tr> <td>002</td> <td></td> </tr> <tr> <td>004</td> <td></td> </tr> <tr> <td>008*</td> <td></td> </tr> <tr> <td>009†</td> <td></td> </tr> <tr> <td>081</td> <td></td> </tr> <tr> <td>082</td> <td></td> </tr> </tbody> </table> <p>* 008 spool has closed crossover. † 009 spool has open crossover.</p>	Code	Symbol	001		002		004		008*		009†		081		082		<table border="1"> <thead> <tr> <th>Code</th> <th>Description</th> </tr> </thead> <tbody> <tr> <td>N</td> <td>Nitrile</td> </tr> <tr> <td>V</td> <td>Fluorocarbon</td> </tr> </tbody> </table>	Code	Description	N	Nitrile	V	Fluorocarbon	<table border="1"> <thead> <tr> <th>Code</th> <th>Description</th> </tr> </thead> <tbody> <tr> <td>Omit</td> <td>Standard</td> </tr> <tr> <td>P05</td> <td>Short Stroke</td> </tr> <tr> <td>P10*</td> <td>Monitor Switch</td> </tr> </tbody> </table> <p>* Not CE or CSA approved.</p>	Code	Description	Omit	Standard	P05	Short Stroke	P10*	Monitor Switch	<table border="1"> <thead> <tr> <th>Code</th> <th>Description</th> <th>Symbol</th> </tr> </thead> <tbody> <tr> <td>B</td> <td>Two position, spring offset operator at "A" port end.</td> <td></td> </tr> <tr> <td>H</td> <td>Two position, spring offset operator at "B" port end.</td> <td></td> </tr> </tbody> </table> <p>Valve schematic symbols are per NFPA/ANSI standards, providing flow P to A when energized. Note flow paths reverse sides for #008 and #009 spools.</p>	Code	Description	Symbol	B	Two position, spring offset operator at "A" port end.		H	Two position, spring offset operator at "B" port end.	
Code	Description																																																		
C	Cam (90° to mounting surface)																																																		
D	Cam parallel to mounting surface																																																		
G	Cam Lever																																																		
Code	Symbol																																																		
001																																																			
002																																																			
004																																																			
008*																																																			
009†																																																			
081																																																			
082																																																			
Code	Description																																																		
N	Nitrile																																																		
V	Fluorocarbon																																																		
Code	Description																																																		
Omit	Standard																																																		
P05	Short Stroke																																																		
P10*	Monitor Switch																																																		
Code	Description	Symbol																																																	
B	Two position, spring offset operator at "A" port end.																																																		
H	Two position, spring offset operator at "B" port end.																																																		

Bold: Designates Tier I products and options.

Non-Bold: Designates Tier II products and options. These products will have longer lead times.

Inch equivalents for millimeter dimensions are shown in (**)

A

Cam Operated D1VC and D1VD

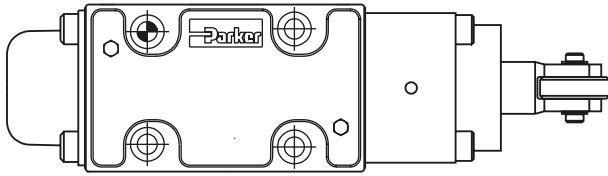

Valve Type	Pre-Travel	Full Spool Travel	Over-Travel
Standard Valve	2.00 (0.079)	9.06 (0.357)	2.03 (0.080)
P05 Short Stroke	0 (0)	7.06 (0.278)	4.03 (0.159)

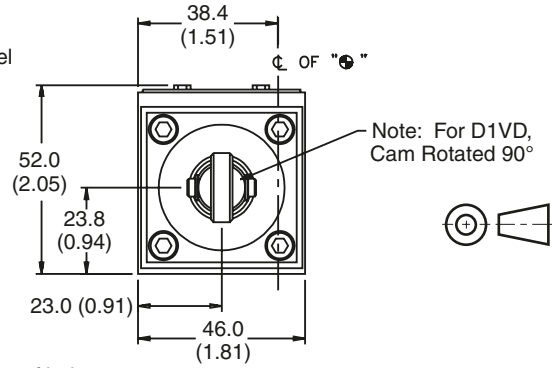
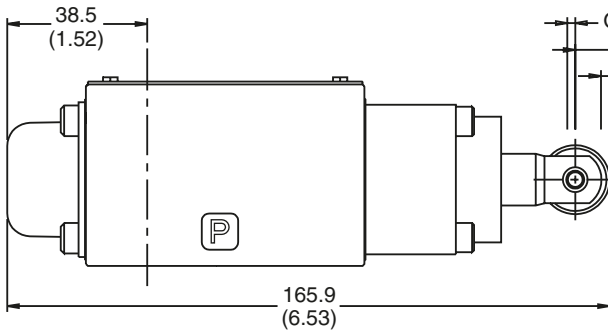

Note: 22.0 mm (0.87") from bottom of bolt hole counterbore to bottom of valve.

Cam Lever Operated D1VG

Valve Type	Pre-Travel	Full Spool Travel	Over-Travel
Standard Valve	6.95 (0.27)	39.63 (1.56)	10.00 (0.39)
P05 Short Stroke	0 (0)	30.12 (1.19)	18.40 (0.72)

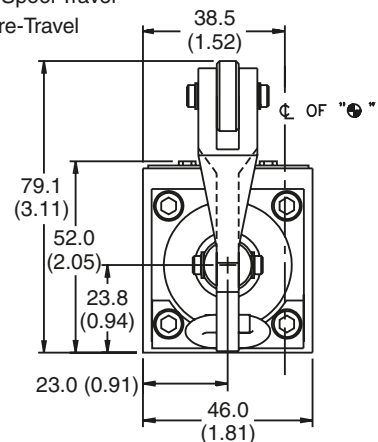
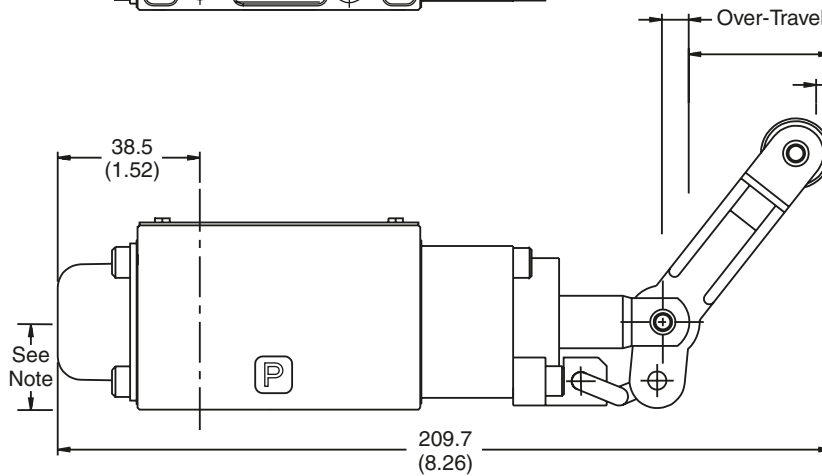
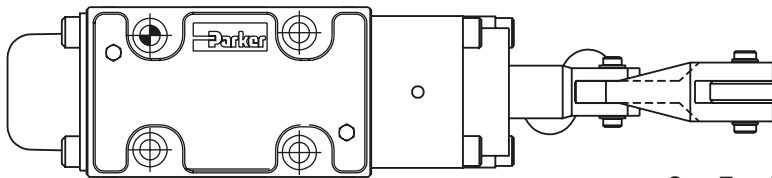

Note: 22.0 mm (0.87") from bottom of bolt hole counterbore to bottom of valve.

General Description

Series D1VL directional control valves are high-performance, 4-chamber, direct operated, lever controlled, 4-way valves. They are available in 2 or 3-position and conform to NFPA's D03, CETOP 3 mounting patterns.

Features

- Spring return or detent styles available
- Heavy duty handle design

Specifications

Mounting Pattern	NFPA D03, CETOP 3, NG 6
Maximum Pressure	Operating: 345 Bar (5000 PSI) Tank Line: 34 Bar (500 PSI)
Maximum Flow	See Reference Data
Force Required to Shift Lever Operator	25 N (5.6 lbs)

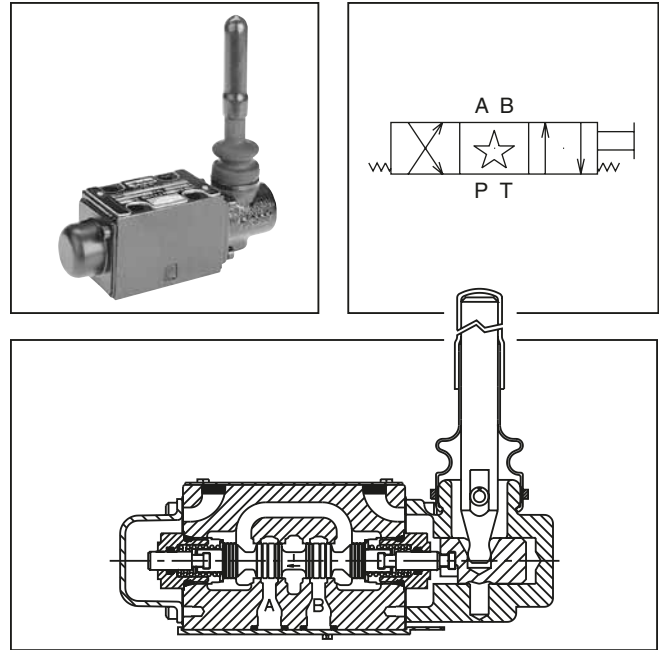

Dimensions

Inch equivalents for millimeter dimensions are shown in (**)

Lever Operated D1VL

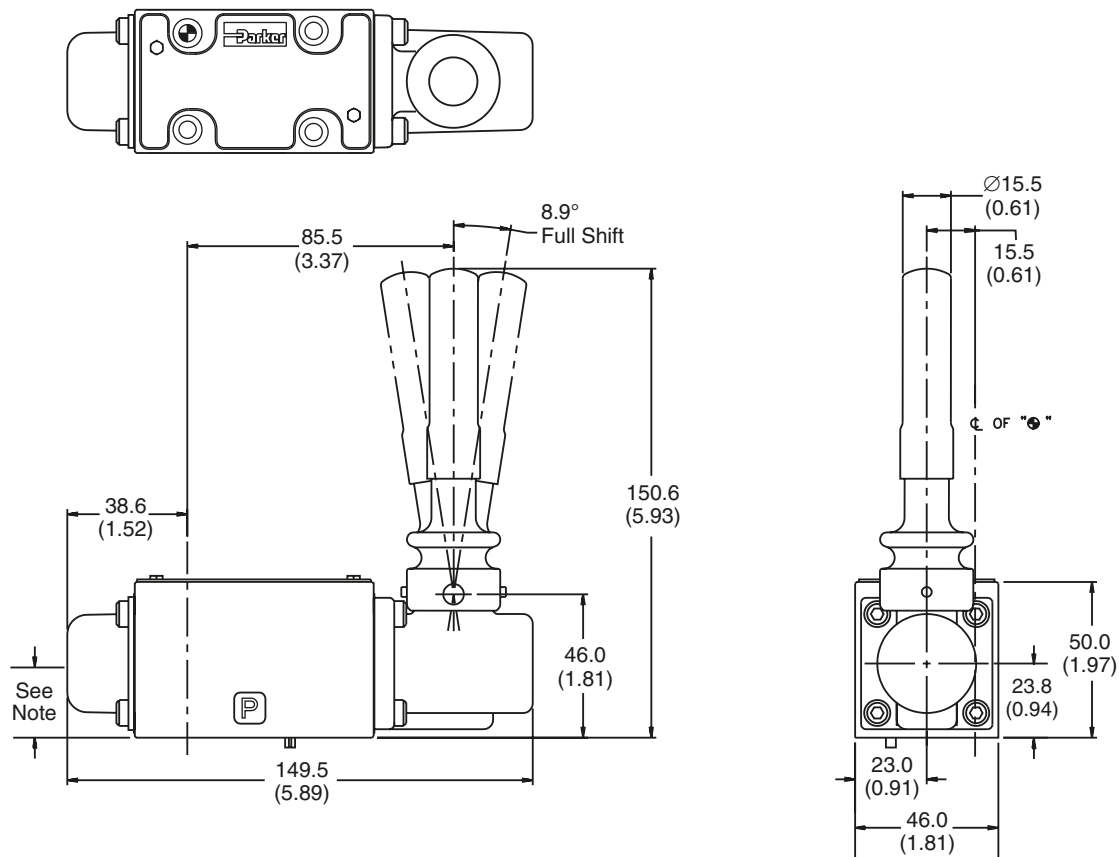

Note: 22.0 mm (0.87") from bottom of bolt hole counterbore to bottom of valve.

D1.indd, dd

A

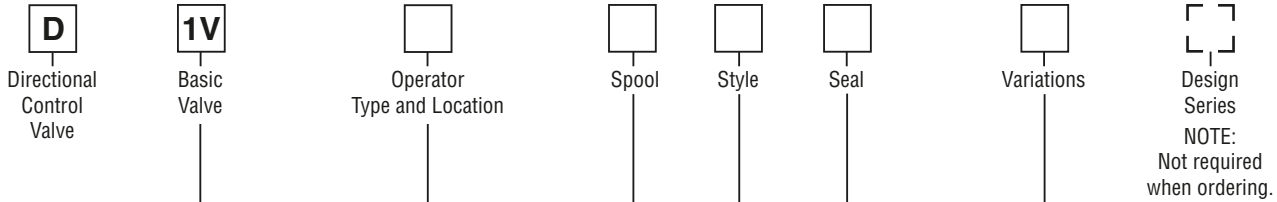

NFPA D03
 CETOP 3

Code	Description
Omit	Standard
P10*	Monitor Switch

* Not available on C,D or N styles. Not CE or CSA approved.

Operator Location (A or B Port End)		
Code	Operator Type	For Valve Style
		B C D E H K N
L	Lever (Standard)	B B B A B B B
LB	Lever (Alternate)	A A A N/A A N/A A

Code	Description
N	Nitrile
V	Fluorocarbon

Code	Symbol
001	
002	
004	
008*	
009†	
081*	
082	

Code	Description	Symbol
B	Two position, spring offset. P to A and B to T in offset position.	
C	Three position, spring centered.	
D	Two position, detent.	
E	Two position, spring centered. P to B and A to T in shifted position.	
H	Two position, spring offset. P to B and A to T in offset position.	
K	Two position, spring centered. P to A and B to T in shifted position.	
N	Three position, detent.	

* 008 and 081 spools have closed crossover.
 † 009 has open crossover.

This condition varies with spool code.

Valve schematic symbols are per NFPA/ANSI standards, providing flow P to A when energizing operator A. Note flow paths reverse sides for #008 and #009 spools in three position valves.

Valve Weight: 1.60 kg (3.5 lbs.)
Standard Bolt Kit: BK209 10-24x1.25
Metric Bolt Kit: BKM209 M5-0.8x30mm Grade 8 bolts required

Seal Kit:
 Nitrile SKD1VL
 Fluorocarbon SKD1VLV

Bold: Designates Tier I products and options.

Non-Bold: Designates Tier II products and options. These products will have longer lead times.

Fluid Recommendations

Premium quality hydraulic oil with a viscosity range between 32-54 cst. (150-250 SSU) at 38°C (100°F) is recommended. The absolute operation viscosity range is from 16-220 cst. (80-1000 SSU). Oil should have maximum anti-wear properties and rust and oxidation treatments.

Fluids and Seals

Valves using synthetic, fire-resistant fluids require special seals. When phosphate ester or its blends are used, FLUOROCARBON seals are required. Water-glycol, (95/5) water-in-oil emulsions, and petroleum oil may be used with NITRILE seals.

Temperature Recommendation

Recommended oil temperature:

-29°C to +71°C (-20°F to +160°F)

Ambient temperature:

AC High Watt ambient temperature cannot exceed 60°C (140°F).

DC High Watt, DC Low Watt and AC Low Watt ambient temperature cannot exceed 71°C (160°F).

Filtration

For maximum valve and system component life, the system should be protected at a contamination level not to exceed 125 particles greater than 10 microns per milliliter of fluid. (SAE Class 4 or better, ISO Code 16/13).

Tank Line Surges

If several valves are piped with a common tank line, flow surges in the line may cause unexpected spool shift. Detent style valves are most susceptible to this. Separate tank lines should be used when line surges are expected in an application.

Recommended Mounting Position

Valve Type	Recommended Mounting Position
Detent (Solenoid)	Horizontal
Spring Centered	Unrestricted
Spring Offset	Unrestricted

Silting

Silting can cause any sliding spool valve to stick and not spring return, if held shifted under pressure for long periods of time. The valve should be cycled periodically to prevent sticking.

Flow Path Data

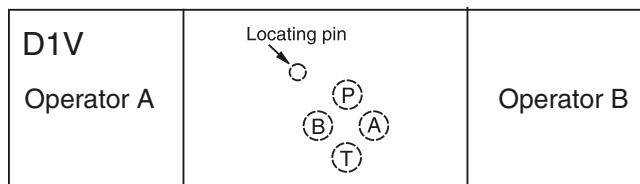

*Note: On valves with 008 or 009 spool, A and/or B operators reverse sides. Flow paths remain the same as viewed from top of valve.

Single Pass Operation

Valve flow ratings are for double pass operation (with equal flow in both paths). When using these components in single pass applications, flow capabilities may be reduced. Consult your local Parker representative for details.

Double Solenoid. With solenoid "A" energized, flow path is P→A and B→T. When solenoid "B" is energized, flow path is P→B and A→T. The center condition on a spring-centered valve exists when both coils are de-energized, or during a complete shift, as the spool passes through center.

Detent and Spring Offset. The center condition exists on detent and spring offset valves only during spool crossover. To shift and hold a detented spool, only a momentary energizing of the solenoid is necessary. The minimum duration of the signal is approximately 0.1 seconds for DC voltages. This position will be held provided the spool center line is in a horizontal plane, and no shock or vibration is present to displace the spool.

Single Solenoid. Spring offset valves can be ordered in styles B, E, F, H, K and M. Flow path data for the various styles are described in the order chart.

Electrical Failure

Should electric power fail, spring offset and spring centered valves will shift to the spring held position. Detented valves will stay in the last position held before power failure. If main flow does not fail or stop simultaneously, machine actuators may continue to function in an undesirable manner or sequence.

Torque Specifications

Torque values recommended for the bolts which mount the valve to the manifold or subplate are as follows:

#10-24 thread (M5-0.8) torque 5.6 Nm (50 in-lbs).

Mounting Pattern — NFPA D03, CETOP 3, NG 6

Inch equivalents for millimeter dimensions are shown in (**)

